

Set 2: State-spaces and Uninformed Search

ICS 271 Fall 2016

Kalev Kask

You need to know

- State-space based problem formulation
 - State space (graph)
- Search space
 - Nodes vs. states
 - Tree search vs graph search
- Search strategies
- Analysis of search algorithms
 - Completeness, optimality, complexity
 - b , d , m

Goal-based agents

Goals provide reason to prefer one action over the other.
We need to predict the future: we need to plan & search

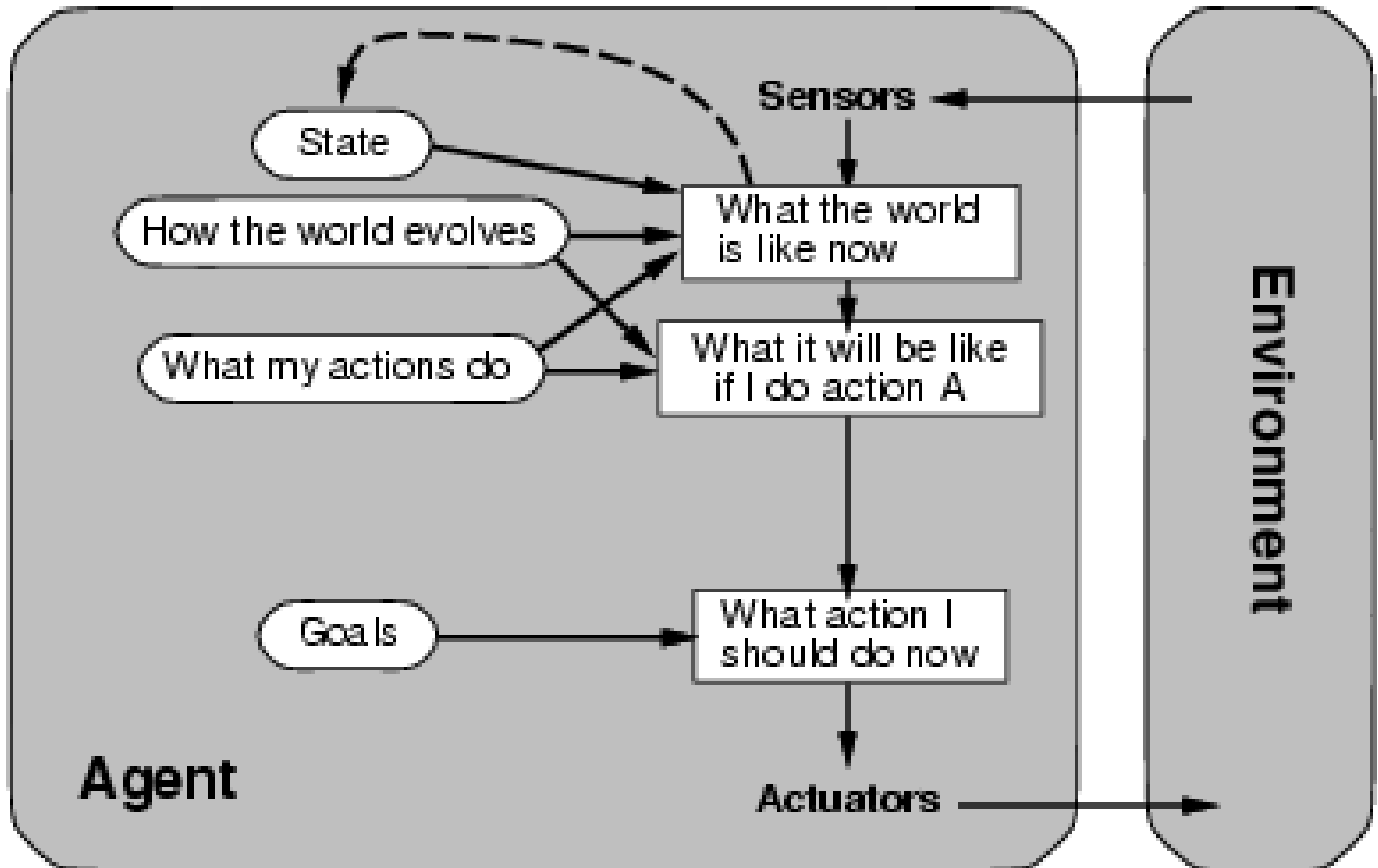

Problem-Solving Agents

- Intelligent agents can solve problems by searching a state-space
- State-space Model
 - the agent's model of the world
 - usually a set of discrete states
 - e.g., in driving, the states in the model could be towns/cities
- Goal State(s)
 - a goal is defined as a desirable state for an agent
 - there may be many states which satisfy the goal
 - e.g., drive to a town with a ski-resort
 - or just one state which satisfies the goal
 - e.g., drive to Mammoth
- Operators(actions)
 - operators are legal actions which the agent can take to move from one state to another

Example: Romania

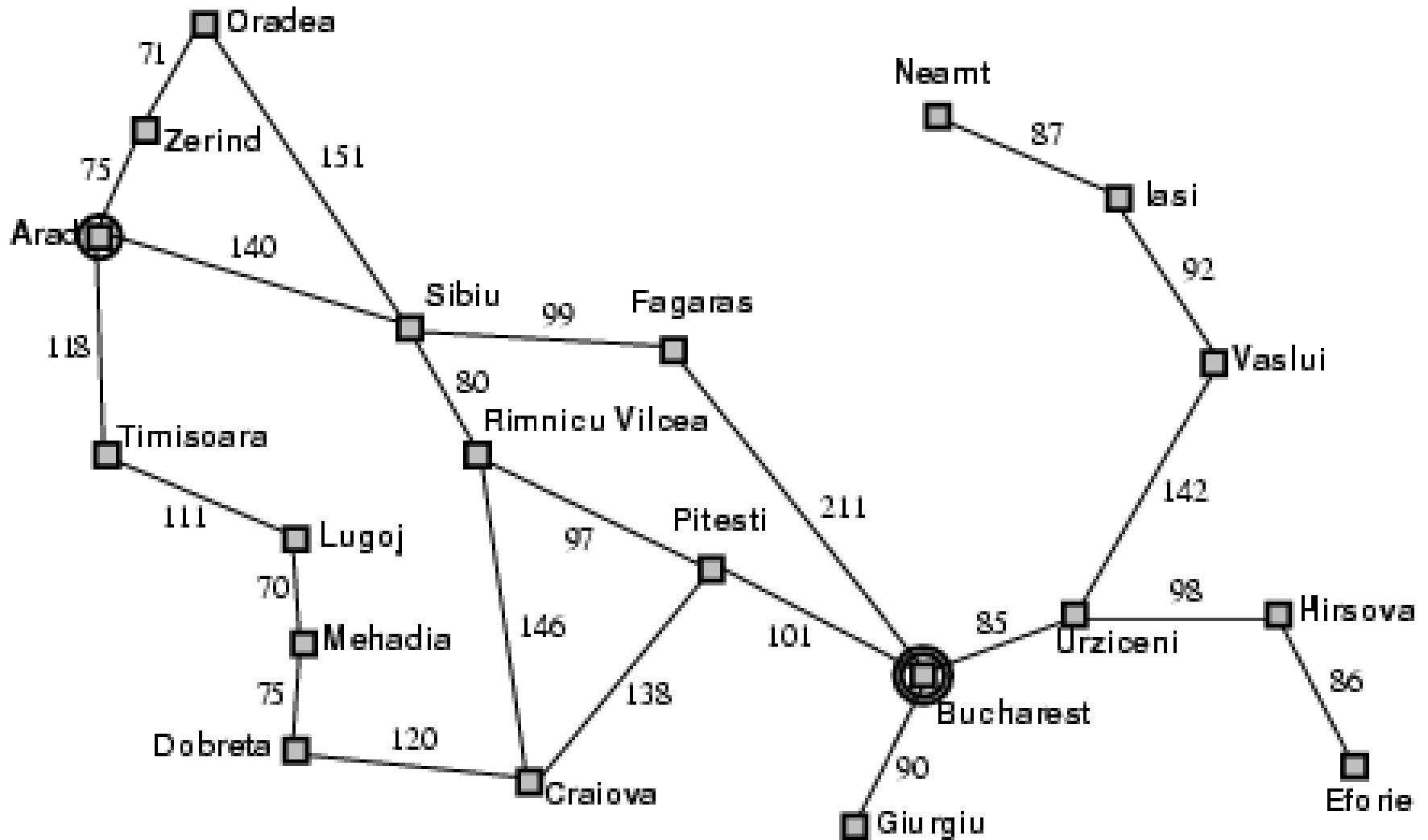

Example: Romania

- On holiday in Romania; currently in Arad.
- Flight leaves tomorrow from Bucharest
- **Formulate goal:**
 - be in Bucharest
- **Formulate problem:**
 - **states:** various cities
 - **actions:** drive between cities
- **Find solution:**
 - sequence of actions (cities), e.g., Arad, Sibiu, Fagaras, Bucharest

Problem Types

- **Static / Dynamic**

Previous problem was static: no attention to changes in environment

- **Observable / Partially Observable / Unobservable**

Previous problem was observable: it knew its initial state.

- **Deterministic / Stochastic**

Previous problem was deterministic: no new percepts were necessary, we can predict the future perfectly

- **Discrete / continuous**

Previous problem was discrete: we can enumerate all possibilities

State-Space Problem Formulation

A **problem** is defined by five items:

states e.g. cities

initial state e.g., "at Arad"

actions or **successor function** $S(x)$ = set of action–state pairs

- e.g., $S(\text{Arad}) = \{ \langle \text{Arad} \rightarrow \text{Zerind}, \text{Zerind} \rangle, \dots \}$

transition function - maps *action & state* \rightarrow *state*

goal test, (or goal state)

e.g., $x = \text{"at Bucharest"}$, $\text{Checkmate}(x)$

path cost (additive)

- e.g., sum of distances, number of actions executed, etc.
- $c(x,a,y)$ is the **step cost**, assumed to be ≥ 0

A **solution** is a sequence of actions leading from the initial state to a goal state

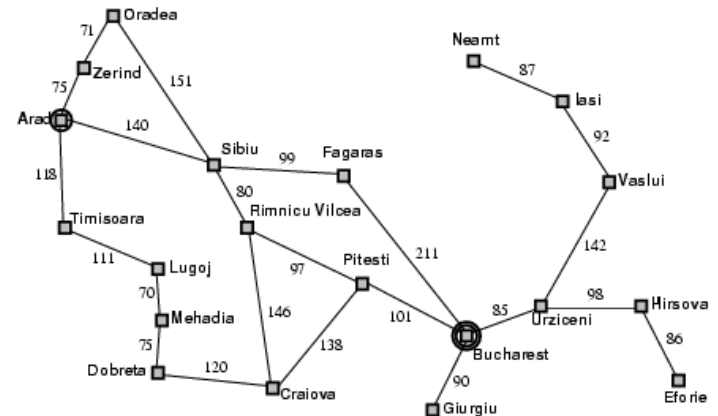

State-Space Problem Formulation

- **A statement of a Search problem has components**
 - 1. States
 - 2. A start state S
 - 3. A set of operators/actions which allow one to get from one state to another
 - 4. transition function
 - 5. A set of possible goal states G , or ways to test for goal states
 - 6. Cost path
- **A solution consists of**
 - a sequence of operators which transform S into a goal state G
- **Representing real problems in a State-Space search framework**
 - may be many ways to represent states and operators
 - key idea: represent only the relevant aspects of the problem (**abstraction**)

Abstraction/Modeling

- **Definition of Abstraction (states/actions)**
 - Process of removing irrelevant detail to create an abstract representation: “high-level”, ignores irrelevant details
- **Navigation Example: how do we define states and operators?**
 - First step is to abstract “the big picture”
 - i.e., solve a map problem
 - nodes = cities, links = freeways/roads (a high-level description)
 - this description is an abstraction of the real problem
 - Can later worry about details like freeway onramps, refueling, etc
- **Abstraction is critical for automated problem solving**
 - must create an approximate, simplified, model of the world for the computer to deal with: real-world is too detailed to model exactly
 - good abstractions retain all important details
 - an abstraction should be easier to solve than the original problem

Robot block world

- Given a set of blocks in a certain configuration,
- Move the blocks into a goal configuration.
- Example :
 - ((A)(B)(C)) \rightarrow (ACB)



Operator Description

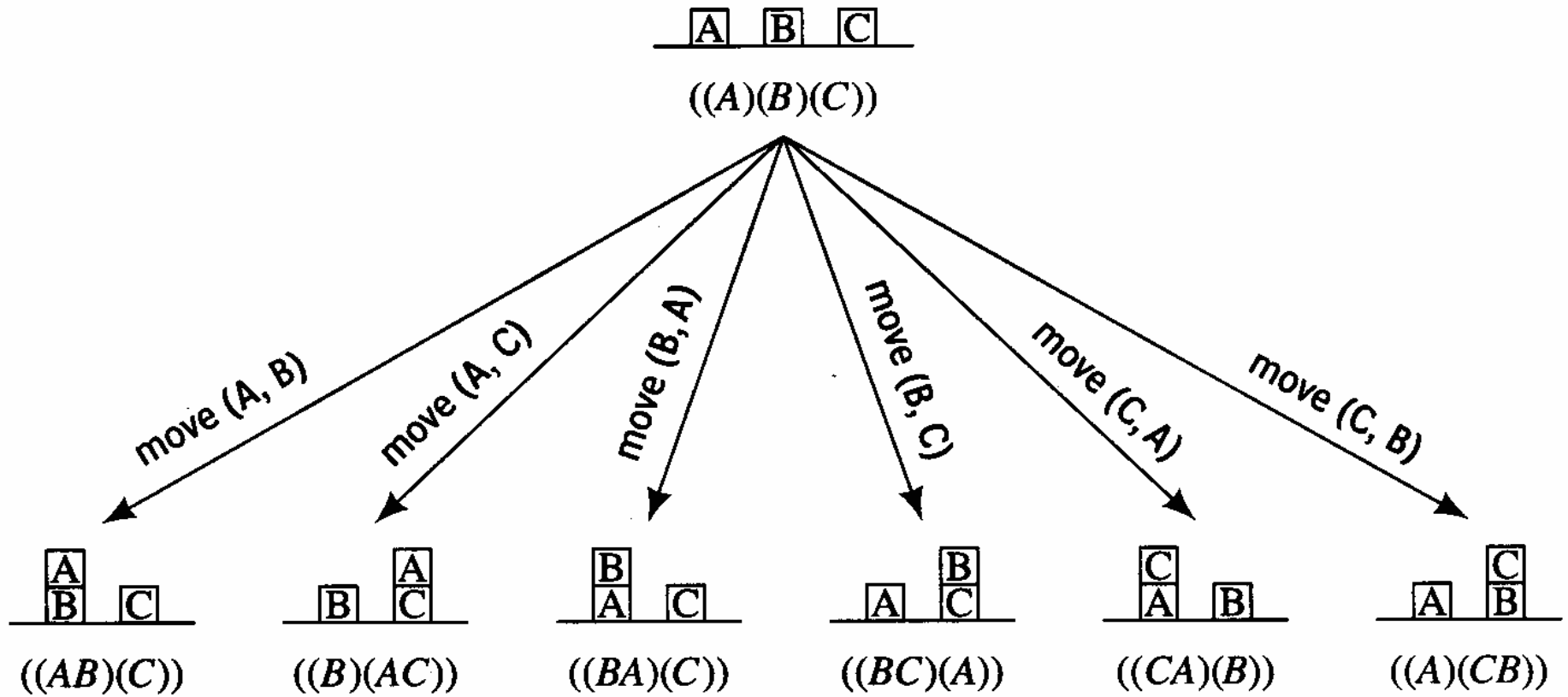

Effects of Moving a Block

The State-Space Graph

- **Problem formulation:**

- Give an abstract description of states, operators, initial state and goal state.

- **Graphs:**

- vertices, edges(arcs), directed arcs, paths

- **State-space graphs:**

- States are vertices
- operators are directed arcs
- solution is a path from start to goal

- **Problem solving activity:**

- Generate a part of the search space that contains a solution

State-space:

1. A set of states
2. A set of “operators”/transitions
3. A start state S
4. A set of possible goal states
5. Cost path

Example: vacuum world

- Observable, start in #5.
Solution?

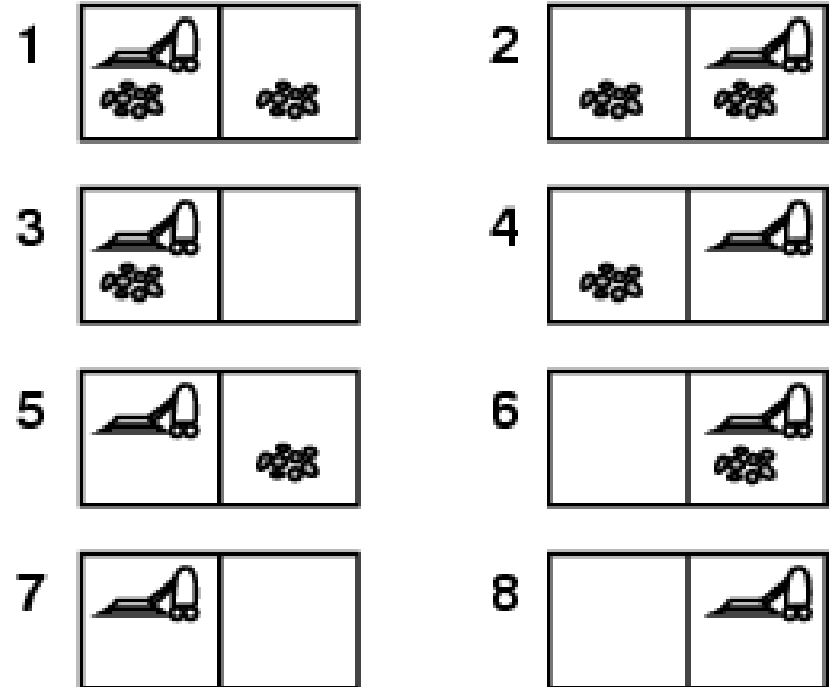

Example: vacuum world

- Observable, start in #5.

Solution?

[Right, Suck]

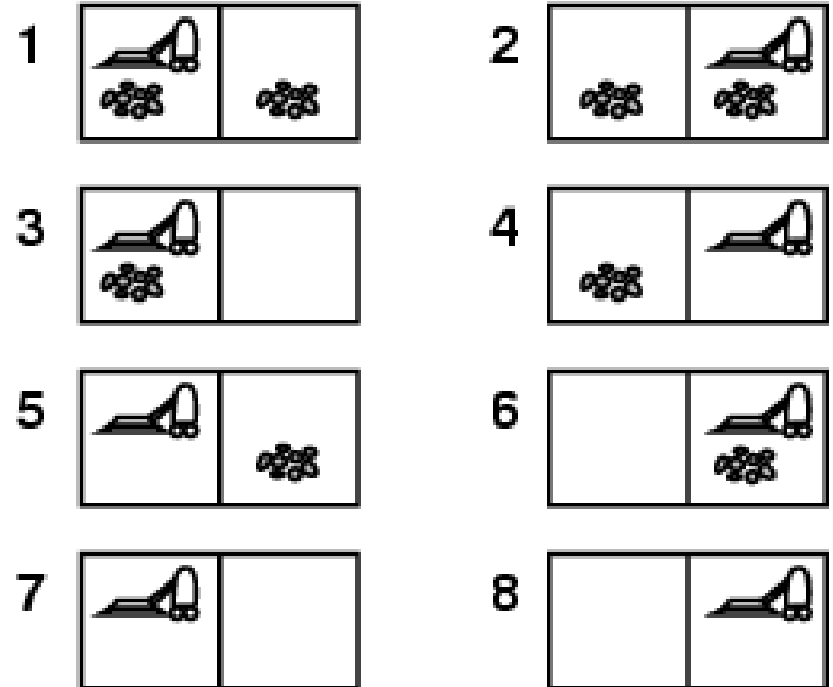

Vacuum world state space graph

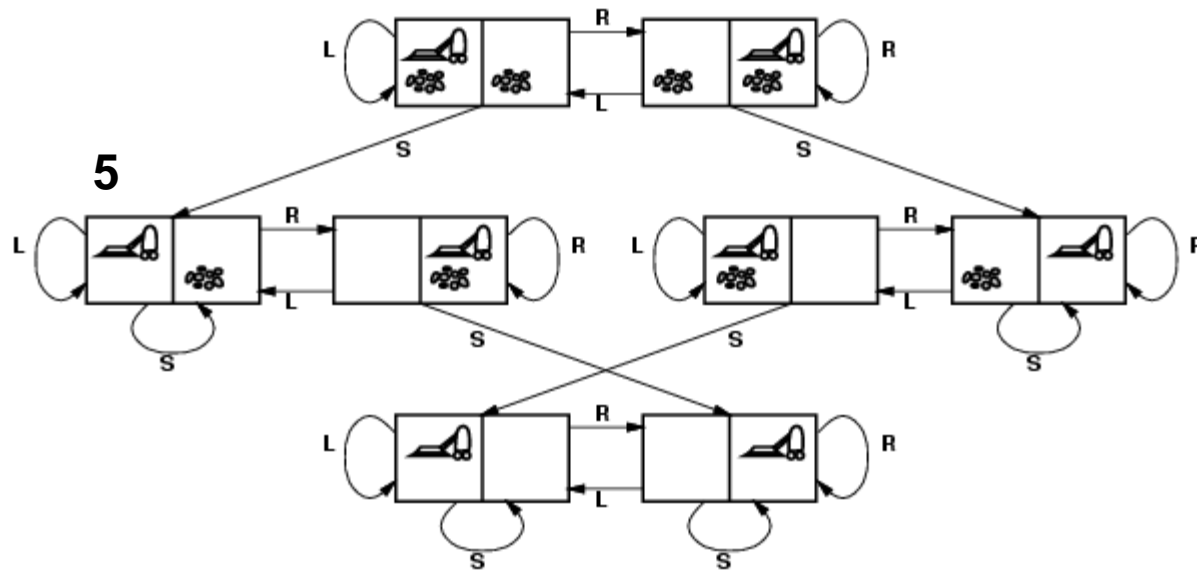

Example: vacuum world

- Unobservable, start in {1,2,3,4,5,6,7,8} e.g., Solution?

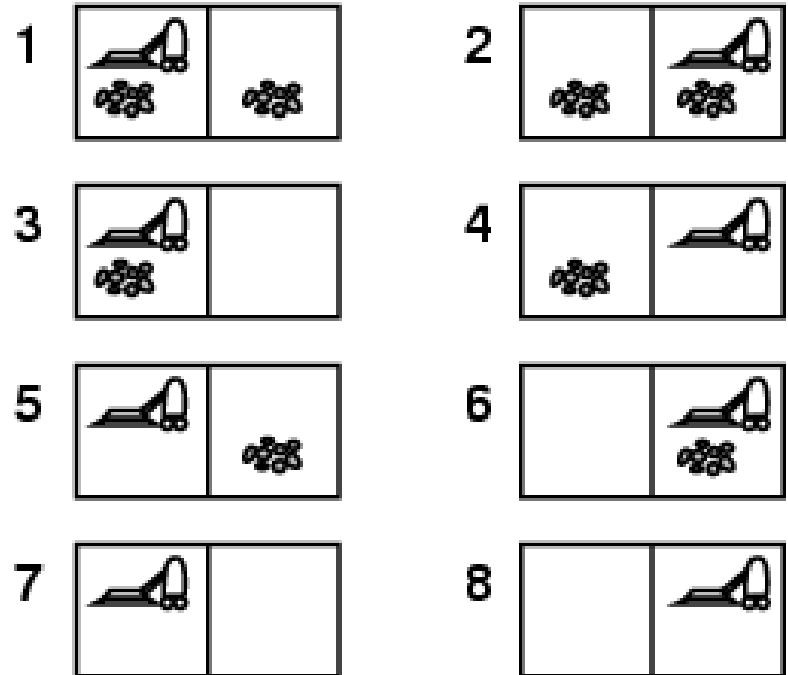

Example: vacuum world

- Unobservable, start in {1,2,3,4,5,6,7,8} e.g.,
Solution?
[Right,Suck,Left,Suck]

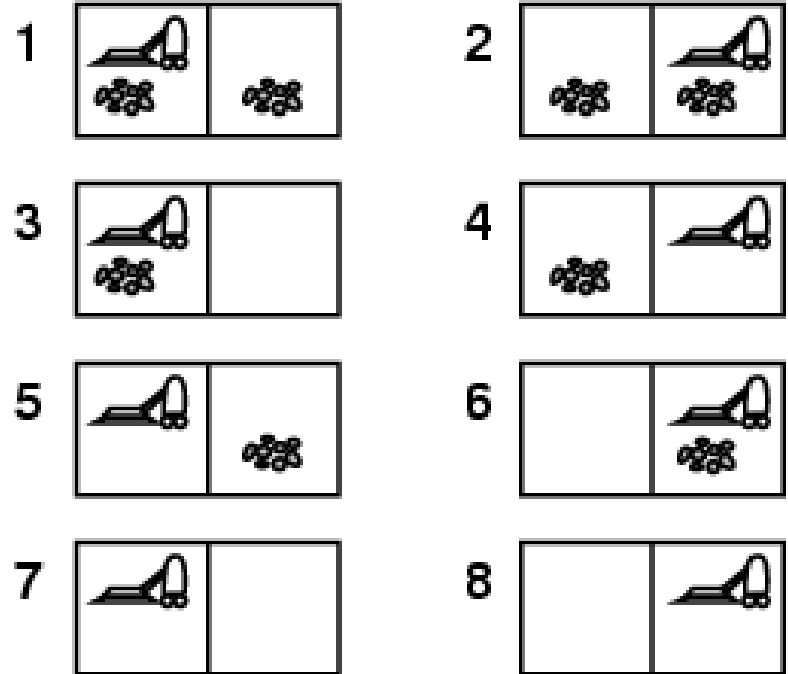

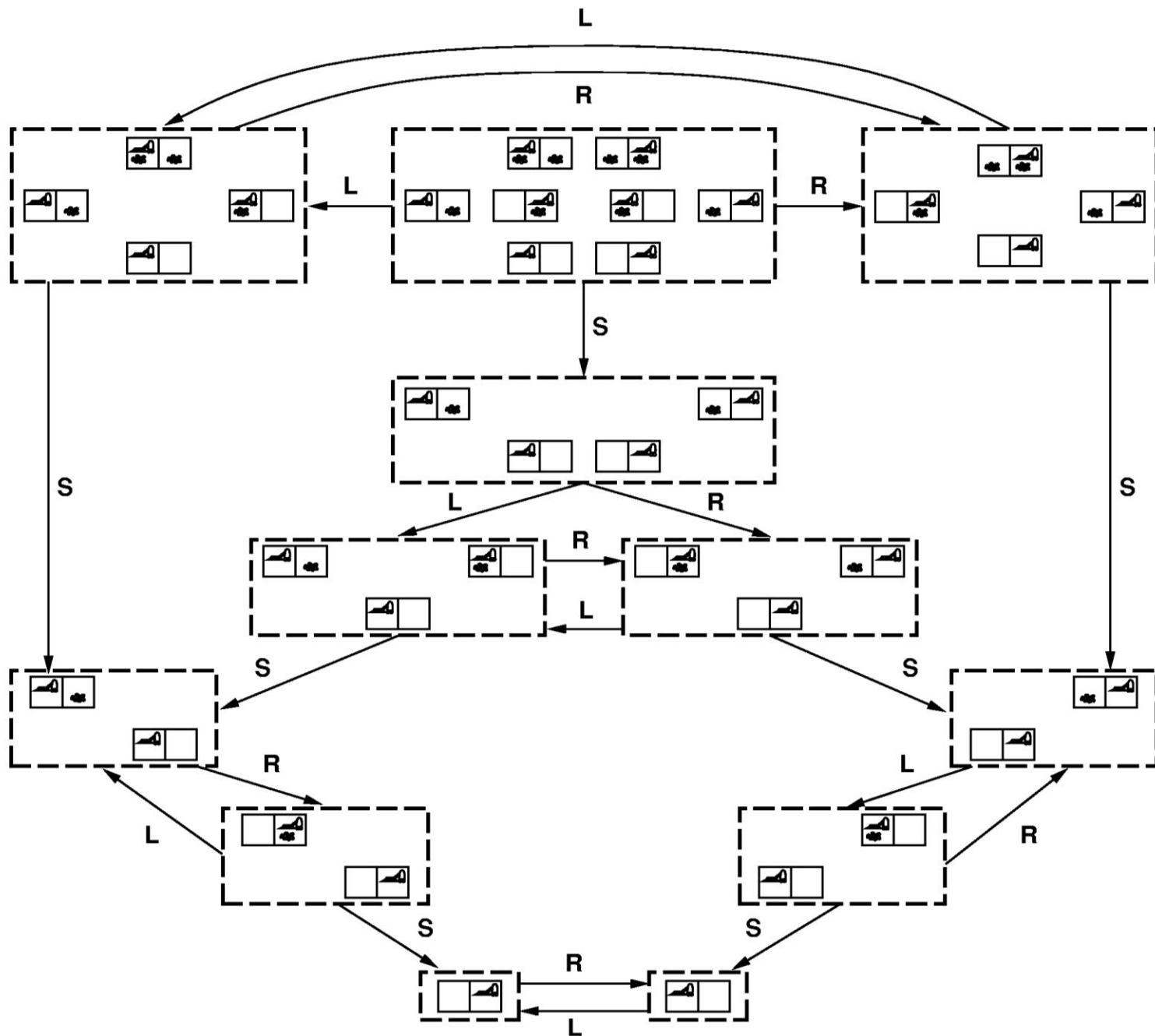

The Traveling Salesperson Problem

- Find the shortest tour that visits all cities without visiting any city twice and return to starting point.
- State:
 - sequence of cities visited
- $S_0 = A$

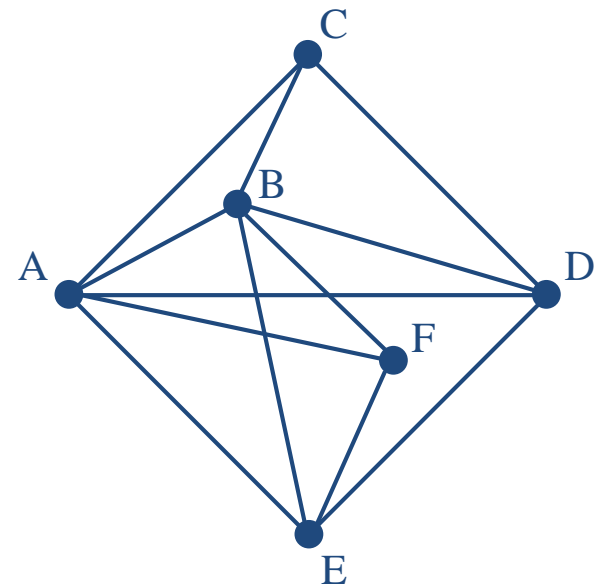

The Traveling Salesperson Problem

- Find the shortest tour that visits all cities without visiting any city twice and return to starting point.
- State: sequence of cities visited
- $S_0 = A$
- Solution = a complete tour

Transition model

$$\{a, c, d\} \Rightarrow \{(a, c, d, x) \mid X \notin a, c, d\}$$

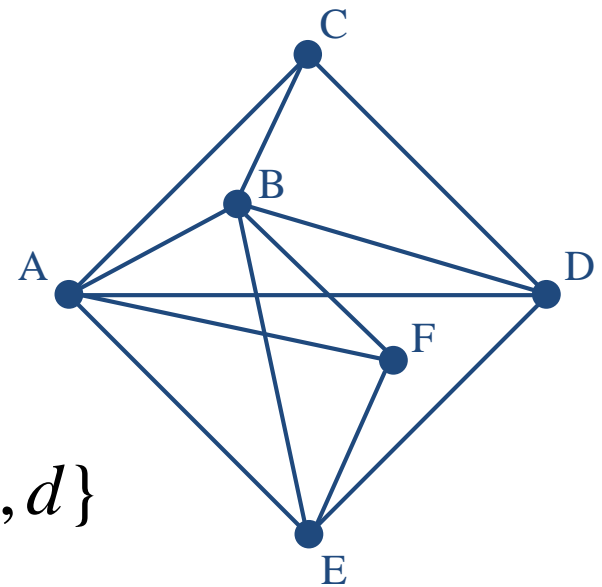

Example: 8-queen problem

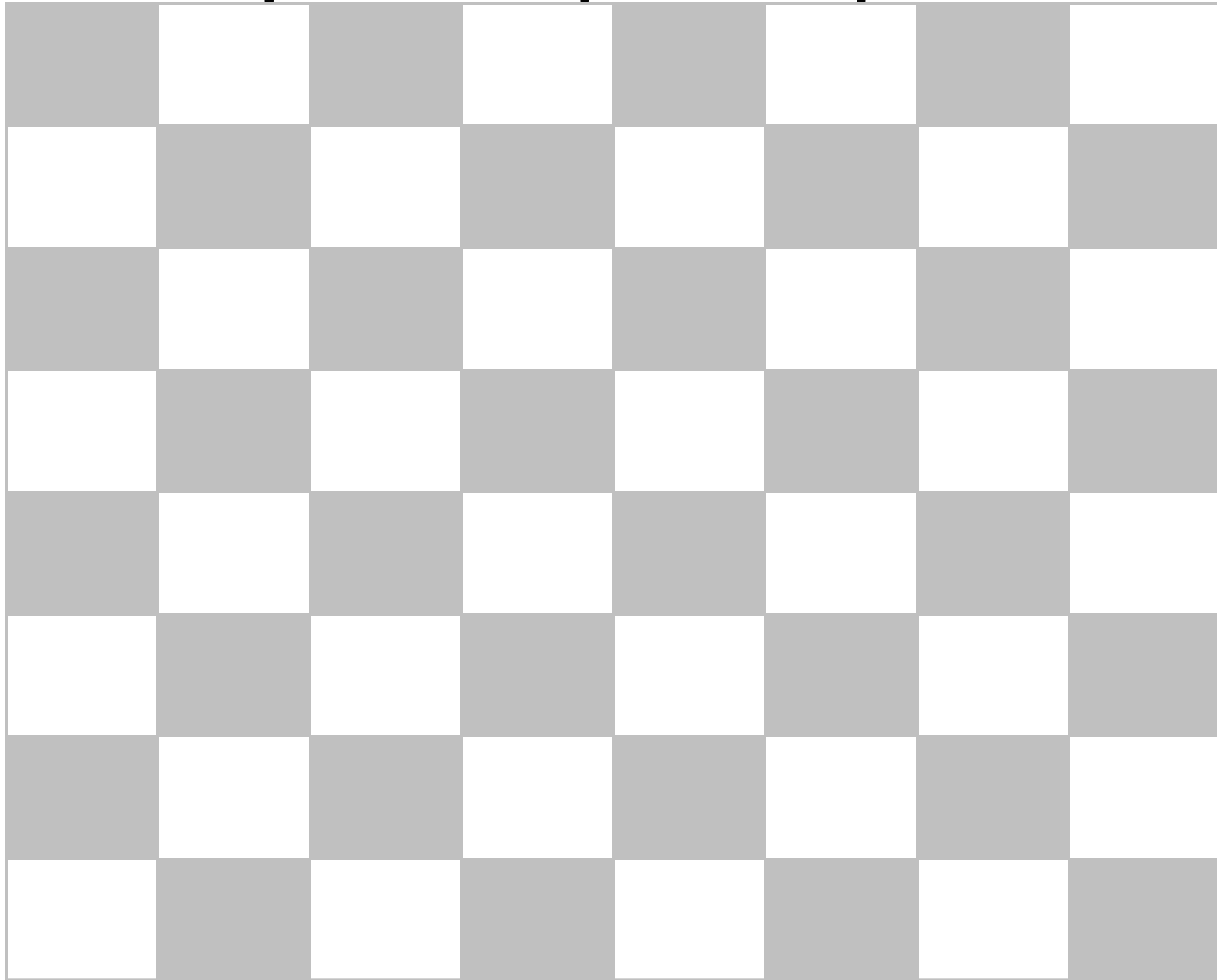

Example: 8-Queens

- states? -any arrangement of $n \leq 8$ queens
 - or arrangements of $n \leq 8$ queens, 1 per column, such that no queen attacks any other (BETTER).
 - or arrangements of $n \leq 8$ queens in leftmost n columns, 1 per column, such that no queen attacks any other (BEST)
- initial state? no queens on the board
- actions? -add queen to any empty column
 - or add queen to leftmost empty column such that it is not attacked by other queens.
- goal test? 8 queens on the board, none attacked.
- path cost? 1 per move

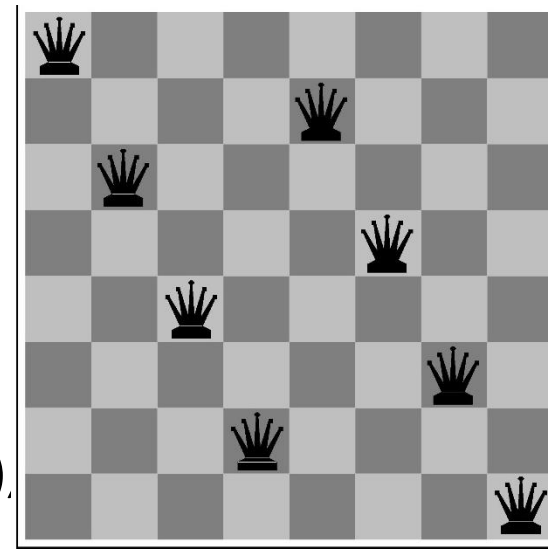

The Sliding Tile Problem



Figure 8.1

Start and Goal Configurations for the Eight-Puzzle

move($x, loc\ y, loc\ z$)

Up
Down
Left
Right

The “8-Puzzle” Problem

Start State

1	2	3
4	■	6
7	5	8



1	2	3
4	5	6
7	■	8



1	2	3
4	5	6
7	8	■

Goal State

Example: robotic assembly

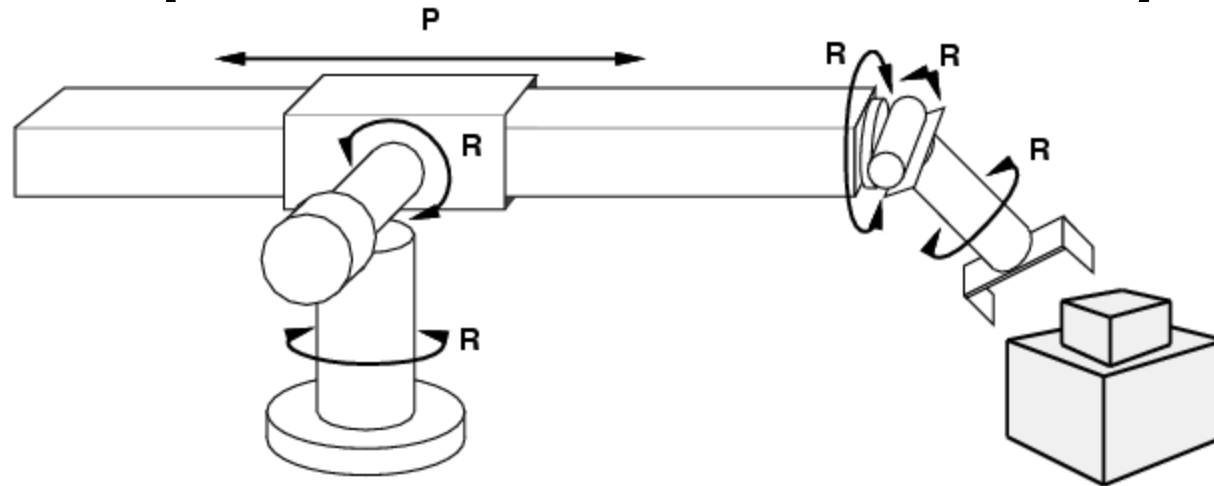

- states?: real-valued coordinates of robot joint angles
parts of the object to be assembled
- actions?: continuous motions of robot joints
- goal test?: complete assembly
- path cost?: time to execute

Formulating Problems; Another Angle

- **Problem types**
 - Satisfying: 8-queen
 - Optimizing: Traveling salesperson
 - For traveling salesperson satisfying easy, optimizing hard
- **Goal types**
 - board configuration
 - sequence of moves
 - A strategy (contingency plan)
- **Satisfying leads to optimizing since “small is quick”**
- For traveling salesperson
 - satisfying easy, optimizing hard
- **Semi-optimizing:**
 - Find a good solution
- **In Russel and Norvig:**
 - single-state, multiple states, contingency plans, exploration problems

Summary so far

- Problem state space formulation
 - states, initial state, goal state(s)/test
 - actions, transition function
- Abstraction
- Search as exploration of the state space graph
 - tree search (no memory) vs graph search (memory)
- States vs nodes; node implementation
- Basic search scheme
- Q : we transformed original problem to path finding on state-space graph; why not apply shortest path finding algorithms?

Searching the State Space

- Exploration of the state space
 - states, operators
 - by generating successors of already explored states (aka **expanding** states)
- Trial and error : pick on possible extension of some path, leaving others aside for the time being.
- **Control strategy** (how to pick a node to expand) generates a search tree.
- Systematic search
 - Do not leave any stone unturned
- Efficiency
 - Do not turn any stone more than once

Tree search example

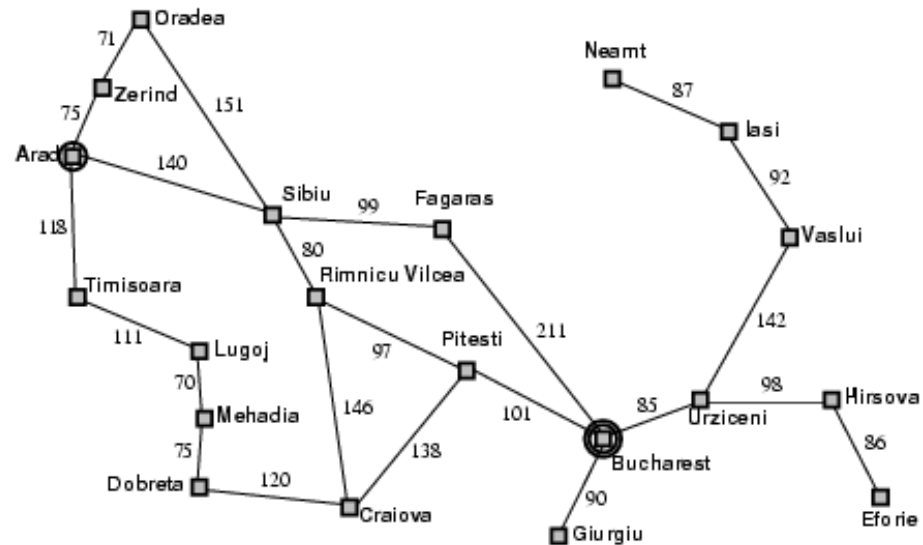
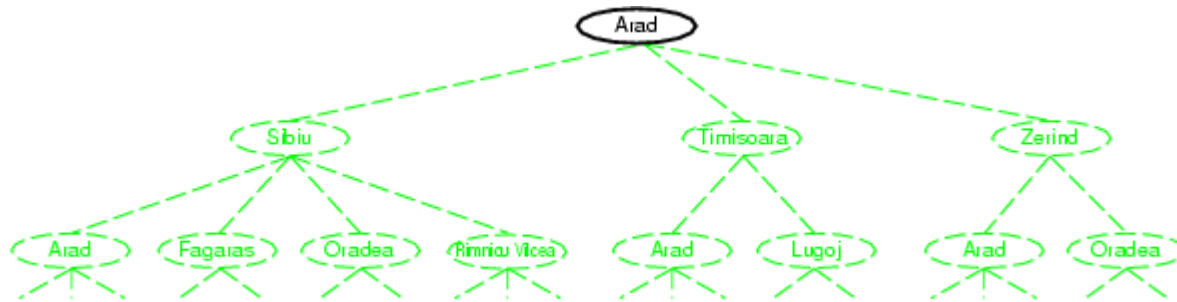

Tree search example

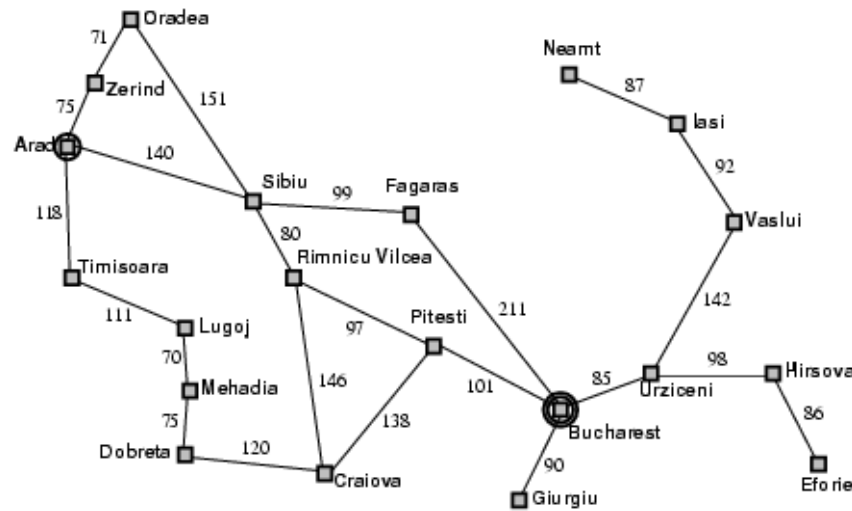
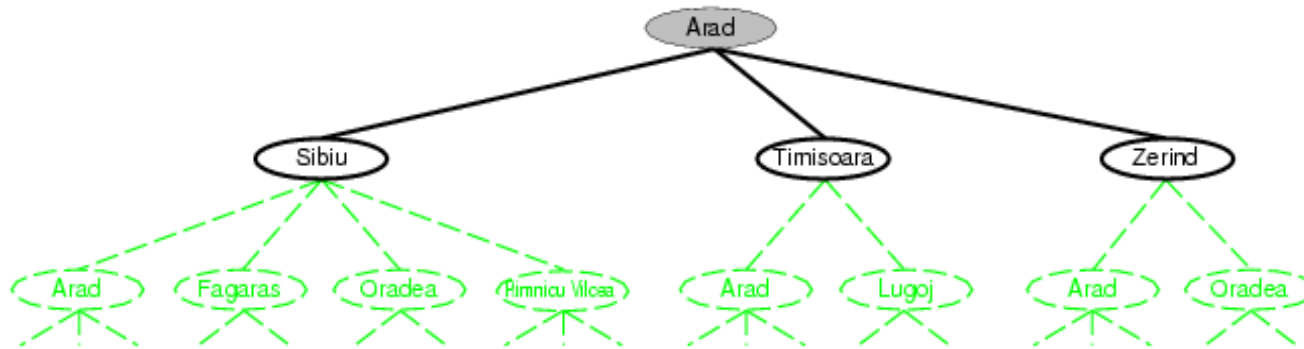

Tree search example

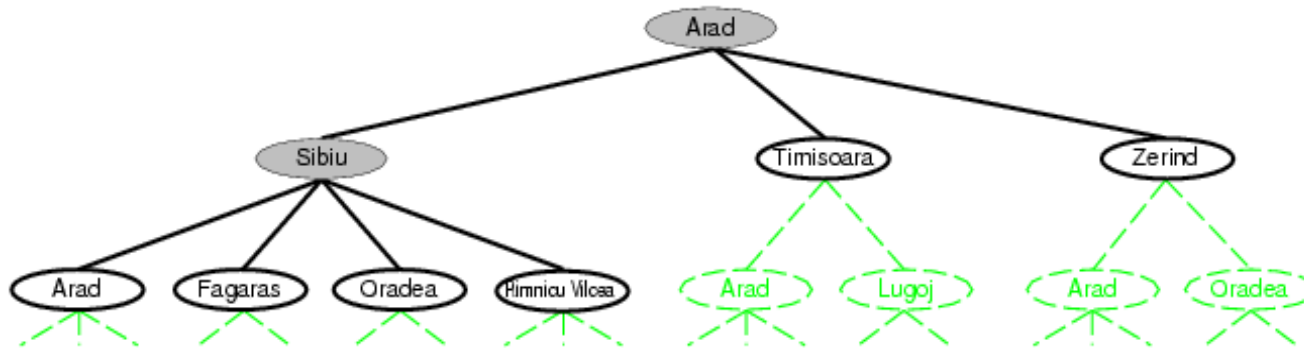

function TREE-SEARCH(*problem, strategy*) **returns** a solution, or failure
initialize the search tree using the initial state of *problem*
loop do
 if there are no candidates for expansion **then return** failure
 choose a leaf node for expansion according to *strategy*
 if the node contains a goal state **then return** the corresponding solution
 else expand the node and add the resulting nodes to the search tree

State-Space Graph of the 8 Puzzle Problem

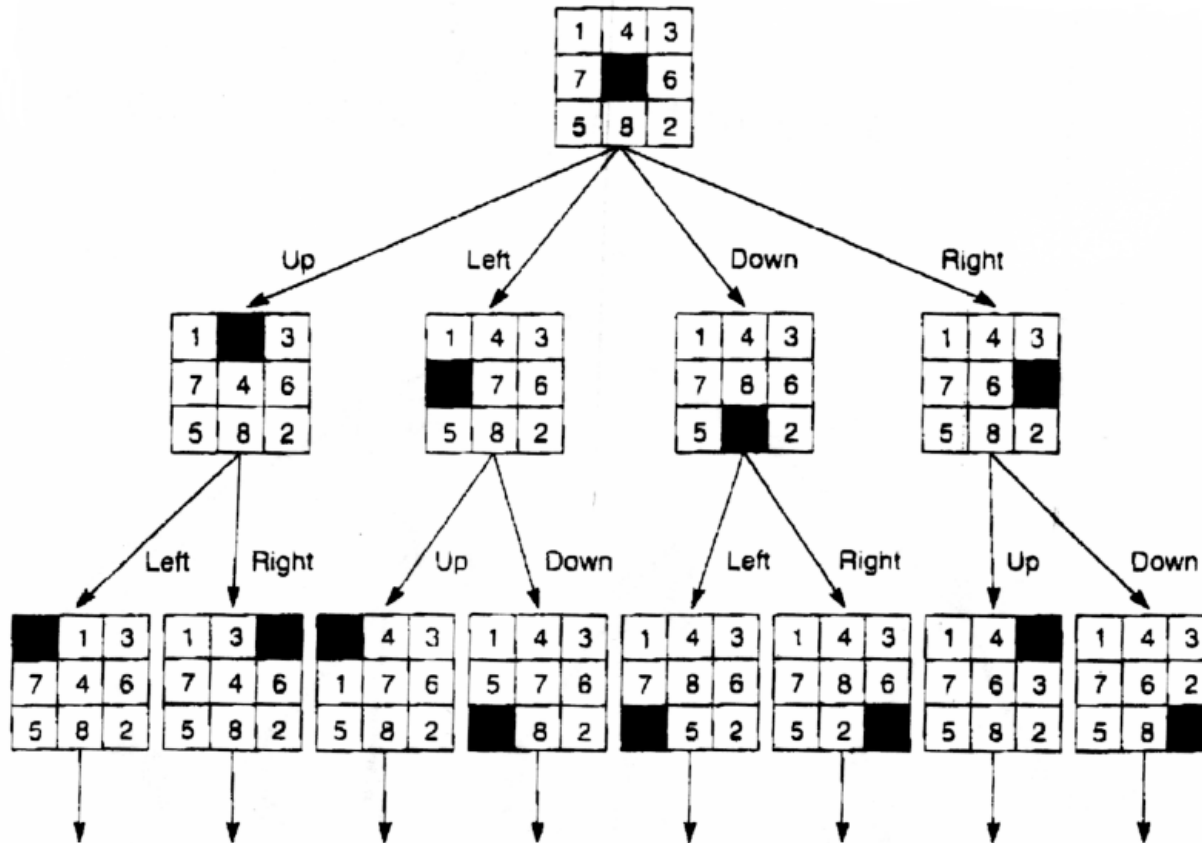
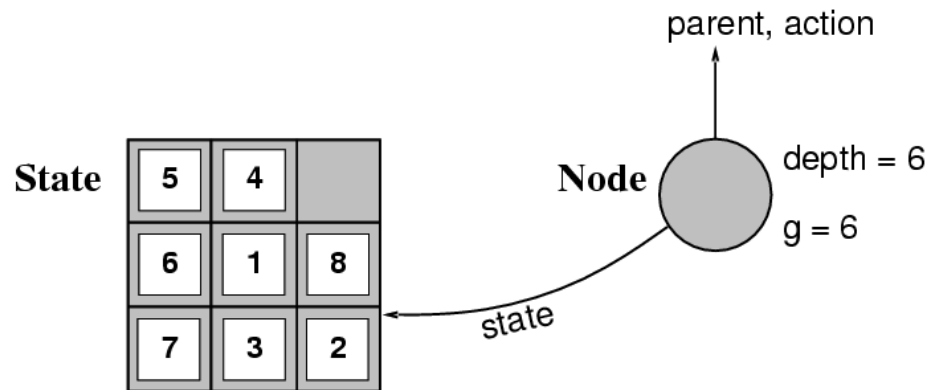

Figure 3.6 State space of the 8-puzzle generated by "move blank" operations.

Implementation

- States vs Nodes
 - A **state** is a (representation of) a physical configuration
 - A **node** is a data structure constituting part of a search tree contains info such as: **state**, **parent node**, **action**, **path cost $g(x)$** , **depth**



- The `Expand` function creates new nodes, filling in the various fields and using the `SuccessorFn` of the problem to create the corresponding states.
- Queue managing frontier :
 - FIFO
 - LIFO
 - priority

Tree-Search vs Graph-Search

- **Tree-search(problem)**, returns a solution or failure
- Frontier \leftarrow initial state
- Loop do
 - If frontier is empty return failure
 - Choose a leaf node and remove from frontier
 - If the node is a goal, return the corresponding solution
 - Expand the chosen node, adding its children to the frontier
 - -----
- **Graph-search(problem)**, returns a solution or failure
- Frontier \leftarrow initial state, *explored* \leftarrow empty
- Loop do
 - If frontier is empty return failure
 - Choose a leaf node and remove from frontier
 - If the node is a goal, **return** the corresponding solution.
 - *Add the node to the explored.*
 - Expand the chosen node, adding its children to the frontier, *only if not in frontier or explored set*

Basic search scheme

- We have 3 kinds of states
 - explored (past) – **only graph search**
 - frontier (current)
 - unexplored (future) – implicitly given
- Initially frontier=start state
- Loop until found solution or exhausted state space
 - pick/remove first node from frontier using search strategy
 - priority queue – FIFO (BFS), LIFO (DFS), g (UCS), f (A*), etc.
 - check if goal
 - add this node to explored,
 - expand this node, add children to frontier (**graph search : only those children whose state is not in explored/frontier list**)
 - Q: what if better path is found to a node already on explored list?

Graph-Search

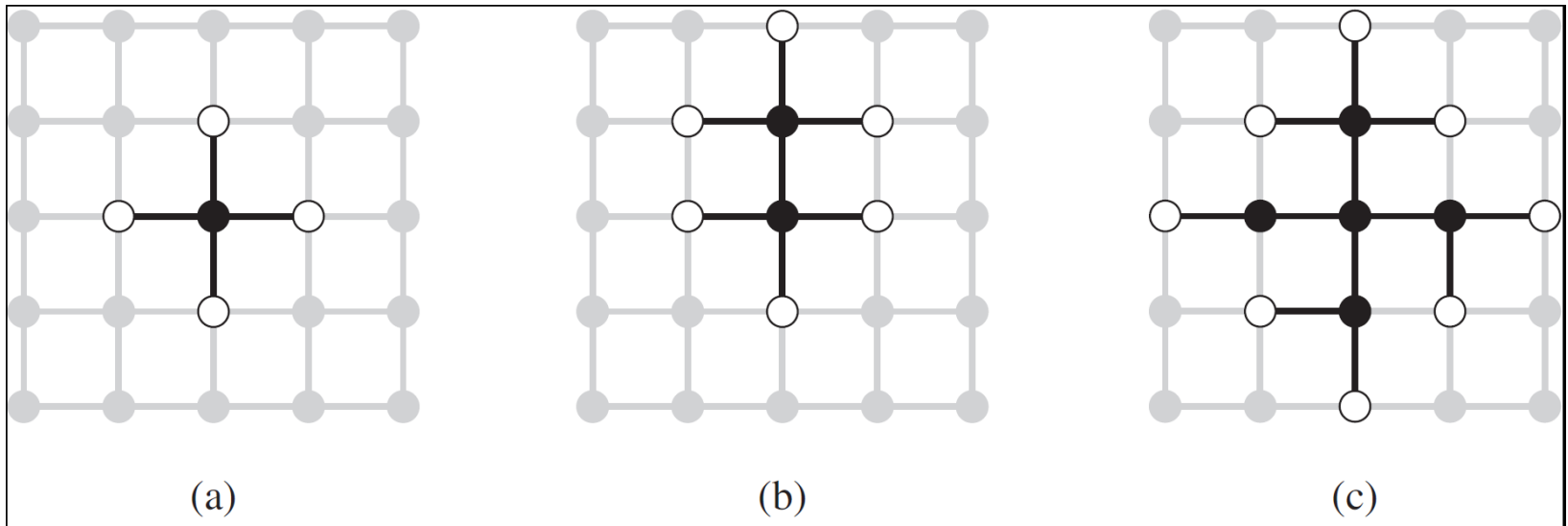
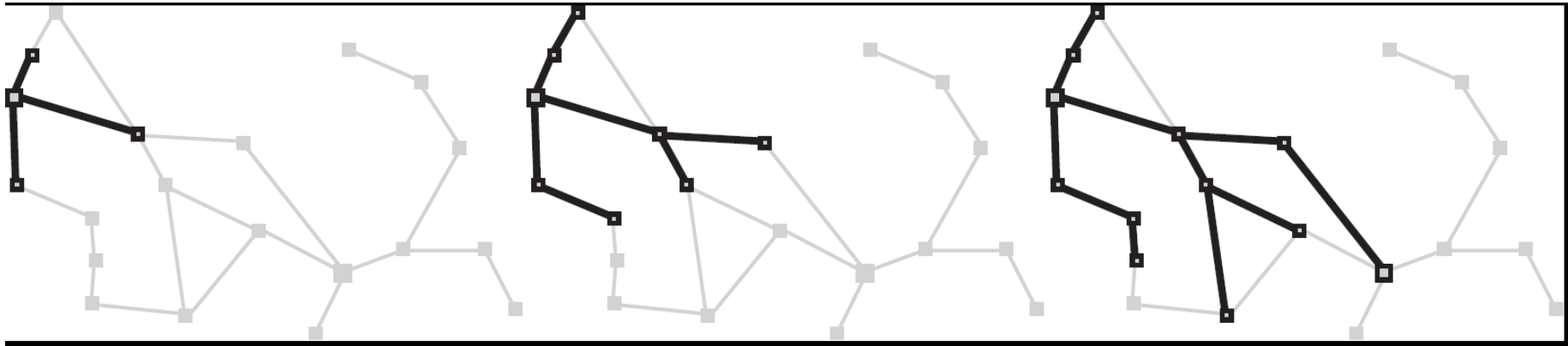

Tree-Search vs. Graph-Search

- Example : Assemble 5 objects {**a**, **b**, **c**, **d**, **e**}
- A state is a bit-vector (length 5), 1=object in assembly
- 11010 = **a**, **b**, **d** in assembly, **c**, **e** not
- State space
 - number of states $2^5 = 32$
 - number of edges $(2^5) \cdot 5 \cdot \frac{1}{2} = 80$
- Tree-search space **Tree-Search vs. Graph-Search**
 - number of nodes $5! = 120$
- State can be reached in multiple ways
 - 11010 can be reached **a+b+d** or **a+d+b** etc.
- Graph-search :
 - three kinds of nodes : **unexplored**, **frontier**, **explored**
 - before adding a node, check if a state is in **frontier** or **explored** set

Tree-Search vs. Graph-Search

- Route finding on rectangular grid (e.g. computer games)
 - Tree search $O(4^d)$
 - Graph search $O(d^2)$

Why Search Can be Difficult

- **At the start of the search, the search algorithm does not know**
 - the size of the tree
 - the shape of the tree
 - the depth of the goal states
- **How big can a search tree be?**
 - say there is a constant branching factor b
 - and one goal exists at depth d
 - search tree which includes a goal can have
 b^d different branches in the tree (worst case)
- **Examples:**
 - $b = 2, d = 10: \quad b^d = 2^{10} = 1024$
 - $b = 10, d = 10: \quad b^d = 10^{10} = 10,000,000,000$

Searching the Search Space

- Uninformed (Blind) search : don't know if a state is "good"
 - Breadth-first
 - Uniform-Cost first
 - Depth-first
 - Iterative deepening depth-first
 - Bidirectional
 - Depth-First Branch and Bound
- Informed Heuristic search : have evaluation fn for states
 - Greedy search, hill climbing, Heuristics
- Important concepts:
 - Completeness : does it always find a solution if one exists ?
 - Time complexity (b, d, m)
 - Space complexity (b, d, m)
 - Quality of solution : optimality = does it always find best solution?

Search strategies

- A search **strategy** is defined by picking the **order of node expansion**
- Strategies are evaluated along the following dimensions:
 - **completeness**: does it always find a solution if one exists?
 - **time complexity**: number of nodes generated
 - **space complexity**: maximum number of nodes in memory
 - **optimality**: does it always find a least-cost solution?
- Time and space complexity are measured in terms of
 - *b*: maximum branching factor of the search tree
 - *d*: depth of the least-cost solution
 - *m*: maximum depth of the state space (may be ∞)

Breadth-First Search

- Expand shallowest unexpanded node
- Frontier: nodes waiting in a queue to be explored, also called **OPEN**
- **Implementation:**
 - *frontier* is a first-in-first-out (FIFO) queue, i.e., new successors go at end of the queue.

Is A a goal state?

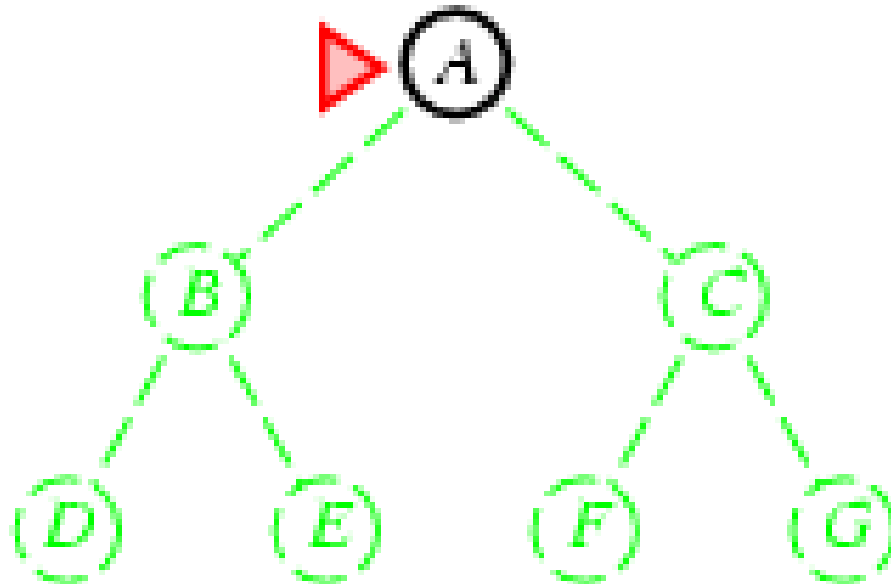

Breadth-First Search

- Expand shallowest unexpanded node
- **Implementation:**
 - *frontier* is a FIFO queue, i.e., new successors go at end

Expand:
frontier = [B,C]

Is B a goal state?

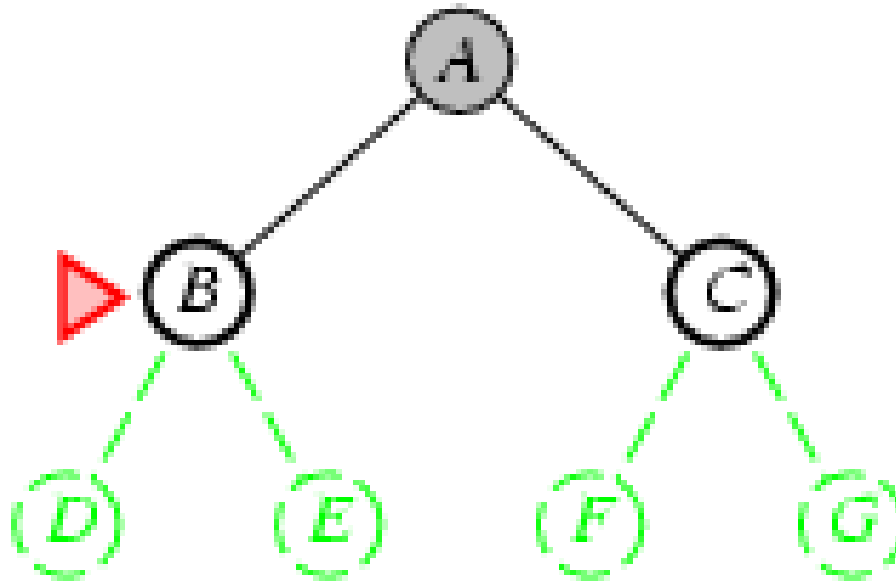

Breadth-First Search

- Expand shallowest unexpanded node
- **Implementation:**
 - *frontier* is a FIFO queue, i.e., new successors go at end

Expand:
frontier=[C,D,E]

Is C a goal state?

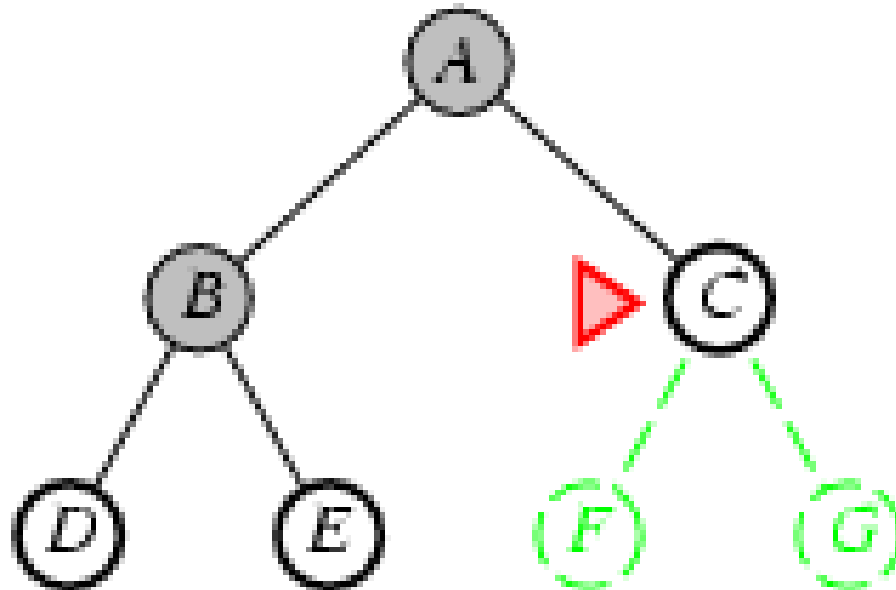

Breadth-First Search

- Expand shallowest unexpanded node
- **Implementation:**
 - *frontier* is a FIFO queue, i.e., new successors go at end

Expand:
frontier=[D,E,F,G]

Is D a goal state?

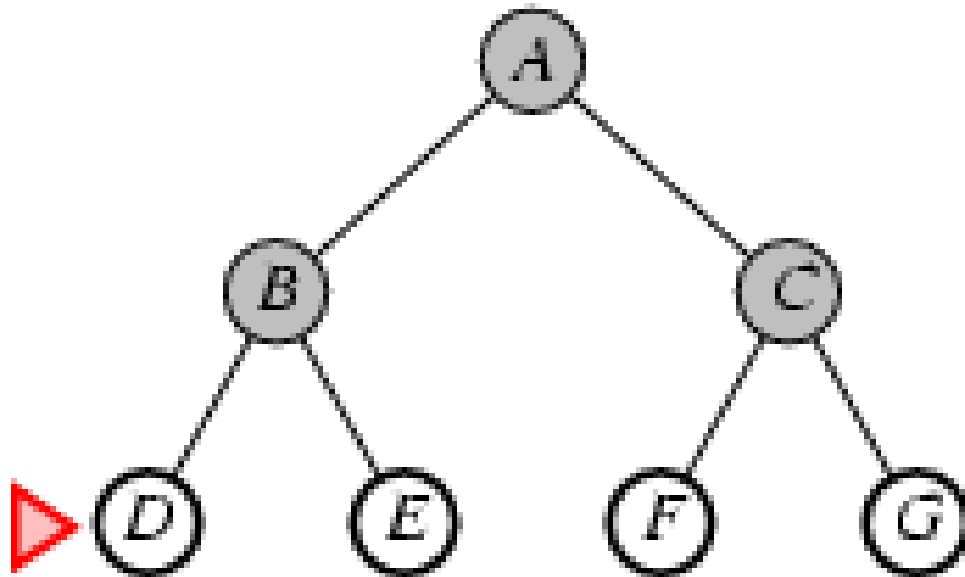

Breadth-First Search

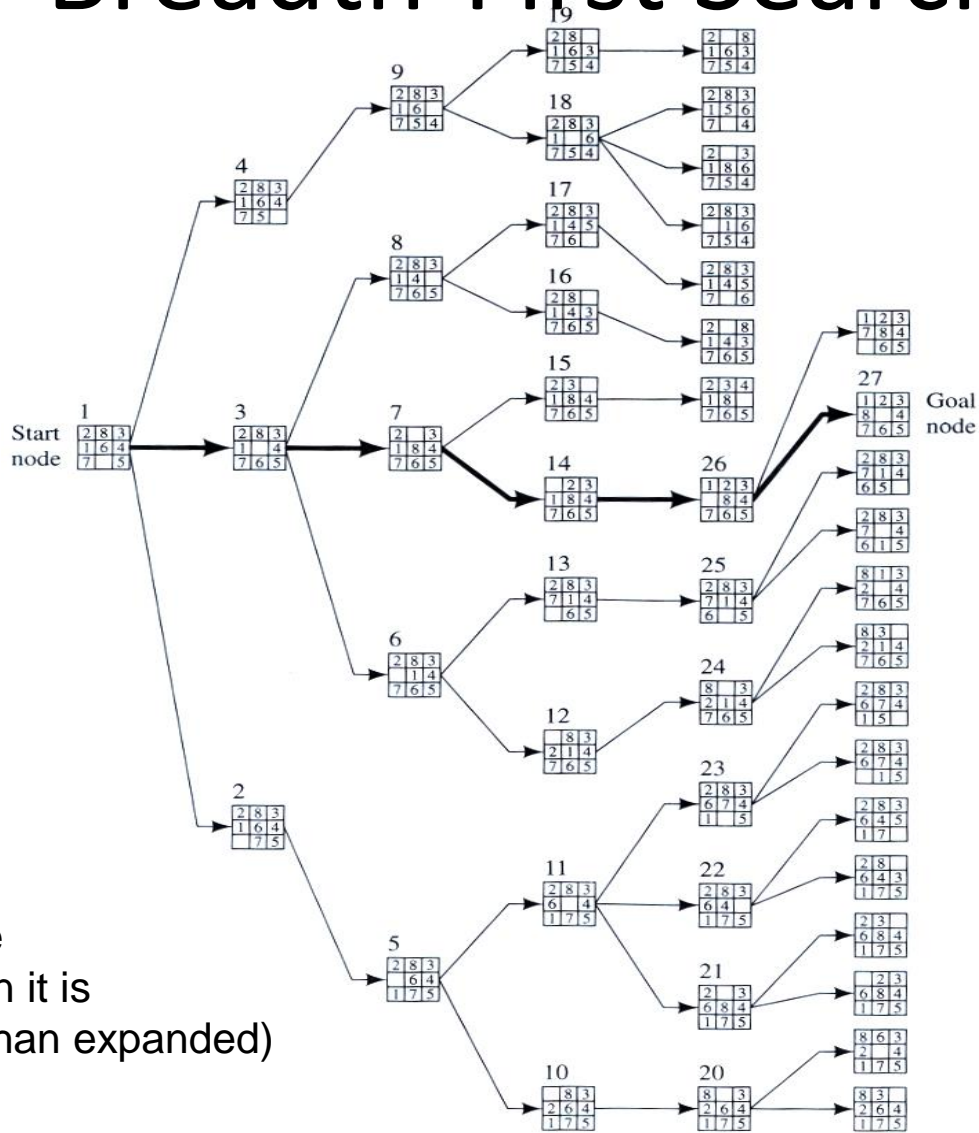

Actually, in BFS we can check if a node is a goal node when it is generated (rather than expanded)

Breadth-First-Search (*)

OPEN = frontier, CLOSED = explored

- 1. Put the start node s on OPEN
- 2. If OPEN is empty exit with failure.
- 3. Remove the first node n from OPEN and place it on CLOSED.
- 4. Expand n , generating all its successors.
 - If child is not in CLOSED or OPEN, then
 - If child is not a goal, then put them at the end of OPEN in some order.
- 5. If n is a goal node, exit successfully with the solution obtained by tracing back pointers from n to s .
- Go to step 2.

* This is graph-search

Example: Map Navigation

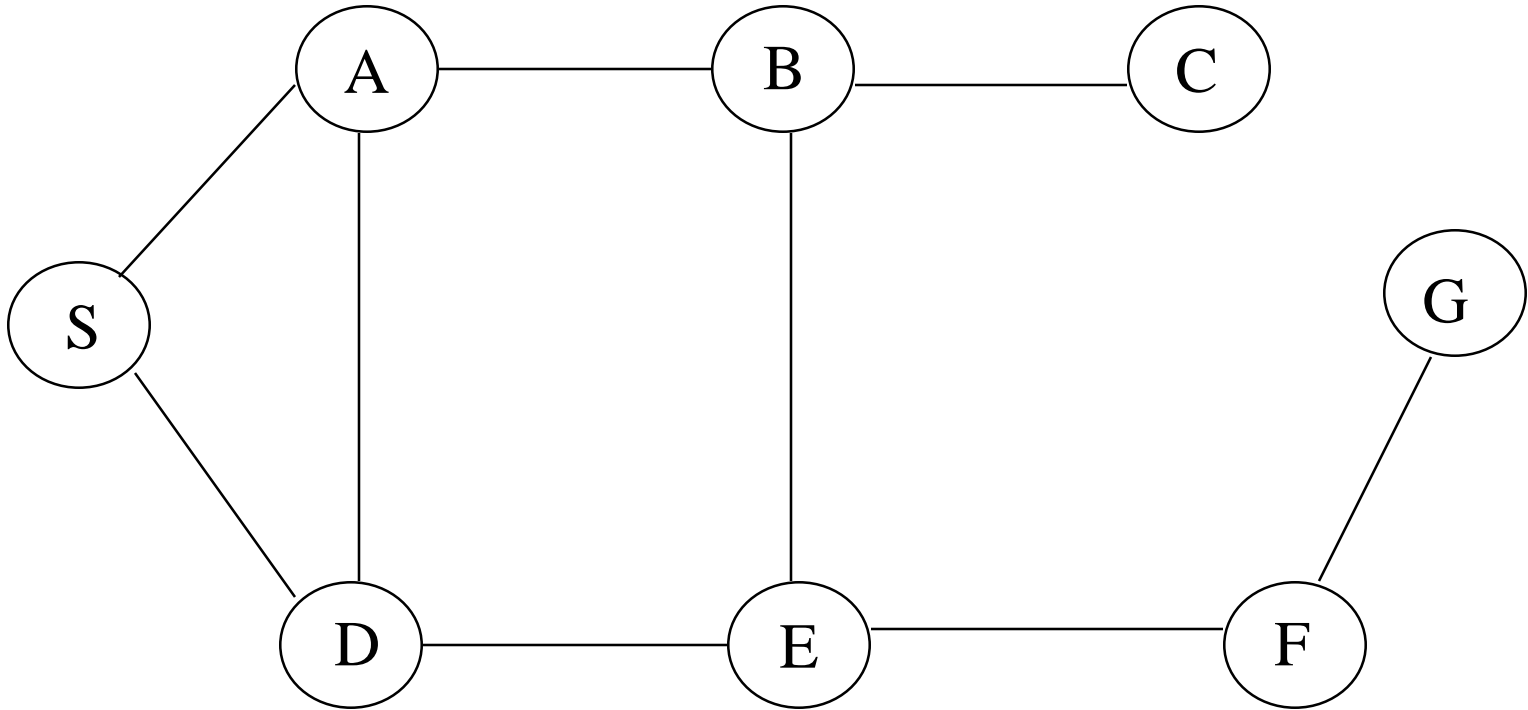

S = start, G = goal, other nodes = intermediate states, links = legal transitions

Breadth-First Search Graph

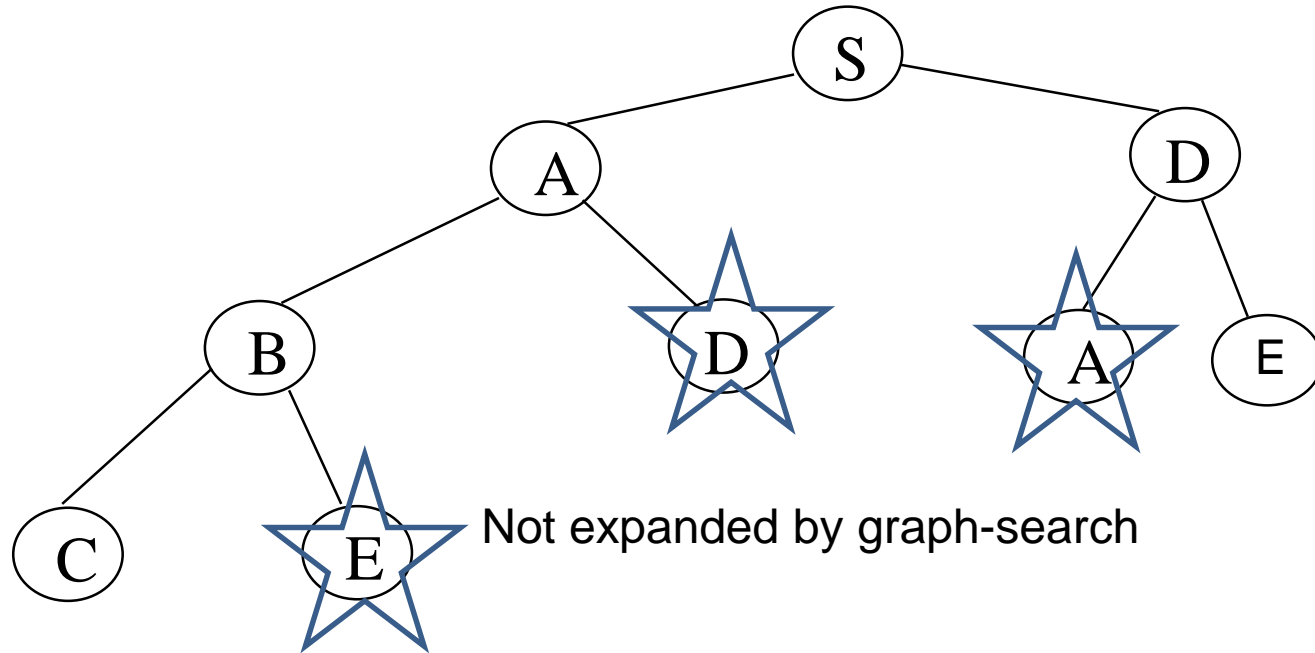

Note: this is the search tree at some particular point in the search.

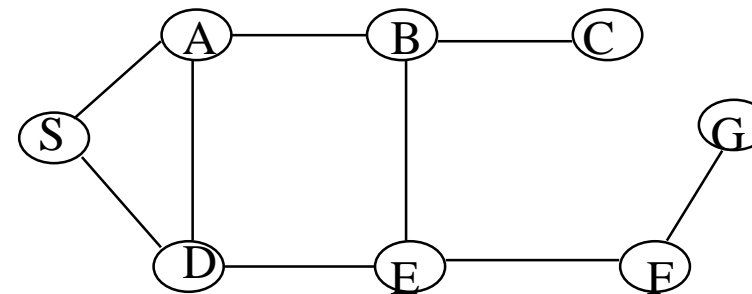

Complexity of Breadth-First Search

- **Time Complexity**

- assume (worst case) that there is 1 goal leaf at the RHS
- so BFS will expand all nodes

$$= 1 + b + b^2 + \dots + b^d$$
$$= \mathbf{O(b^d)}$$

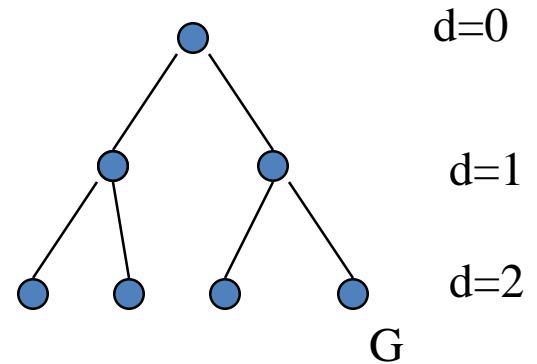

- **Space Complexity**

- how many nodes can be in the queue (worst-case)?
- at depth d there are b^d unexpanded nodes in the Q = $\mathbf{O(b^d)}$

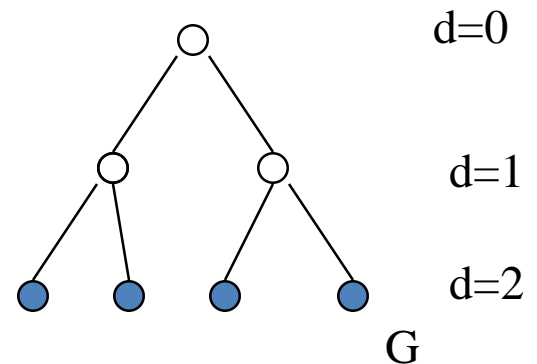

Examples of Time and Memory Requirements for Breadth-First Search

Depth of Solution	Nodes Expanded	Time	Memory
0	1	1 millisecond	100 bytes
2	111	0.1 seconds	11 kbytes
4	11,111	11 seconds	1 megabyte
8	10^8	31 hours	11 giabytes
12	10^{12}	35 years	111 terabytes

Assuming $b=10$, 1000 nodes/sec, 100 bytes/node

Breadth-First Search (BFS) Properties

- Solution Length: optimal
- Expand each node once (can check for duplicates, performs graph-search)
- Search Time: $O(b^d)$
- Memory Required: $O(b^d)$
- Drawback: requires exponential space

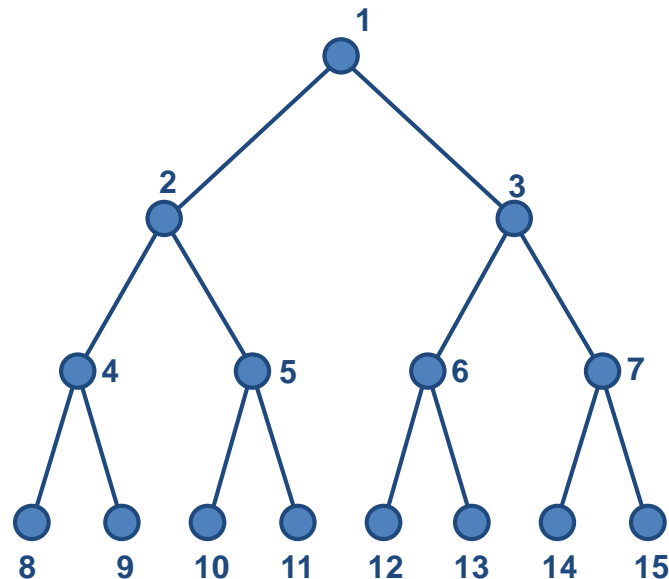

Uniform Cost Search

- Use priority queue to implement frontier
- Expand lowest-cost OPEN node ($g(n)$)
- In BFS $g(n) = \text{depth}(n)$

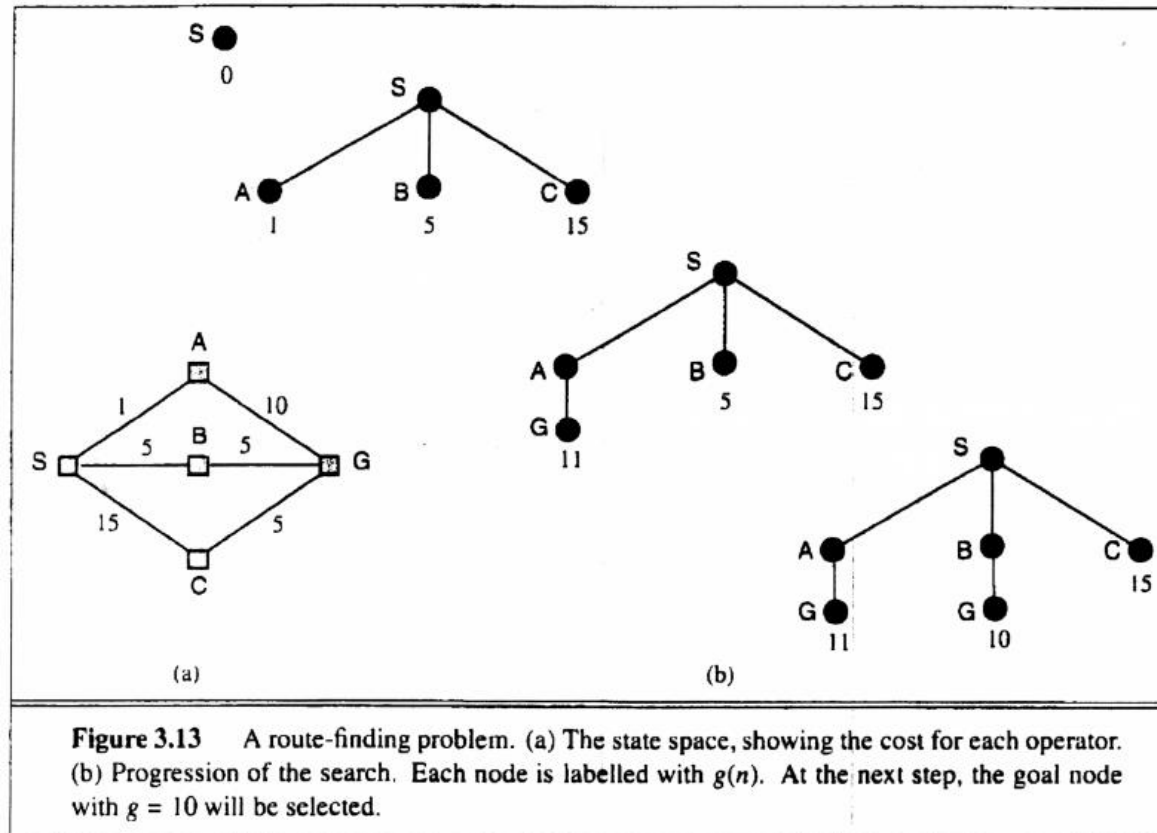

○ Requirement

- $g(\text{successor}(n)) \geq g(n)$

Uniform Cost Search

- Guaranteed to find optimal solution (as long as all steps have >0 cost)
 - When a node is selected for expansion, a shortest path to it has been found
- UCS expands in the order of optimal path cost

Uniform cost search

1. Put the start node s on OPEN
2. If OPEN is empty exit with failure.
3. Remove the first node n from OPEN and place it on CLOSED.
4. If n is a goal node, exit successfully with the solution obtained by tracing back pointers from n to s .
5. Otherwise, expand n , generating all its successors attach to them pointers back to n , and put them in OPEN *in order of shortest cost*
6. Go to step 2.

DFS Branch and Bound

At step 4: compute the cost of the solution found and update the upper bound U .

At step 5: expand n , generating all its successors attach to them pointers back to n , and put on top of OPEN.

Compute cost of partial path to node and prune if larger than U .

Depth-First Search

- Expand *deepest* unexpanded node
- **Implementation:**
 - *frontier* = Last In First Out (LIFO) queue, i.e., put successors at front

Is A a goal state?

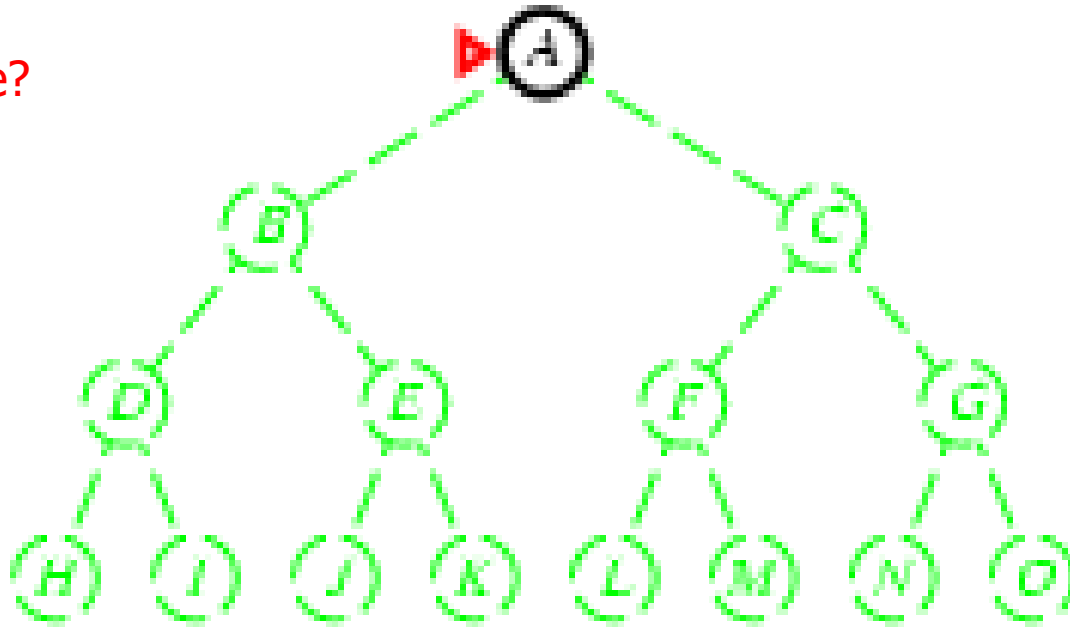

Depth-first search

- Expand deepest unexpanded node
- **Implementation:**
 - *frontier* = LIFO queue, i.e., put successors at front

queue=[B,C]

Is B a goal state?

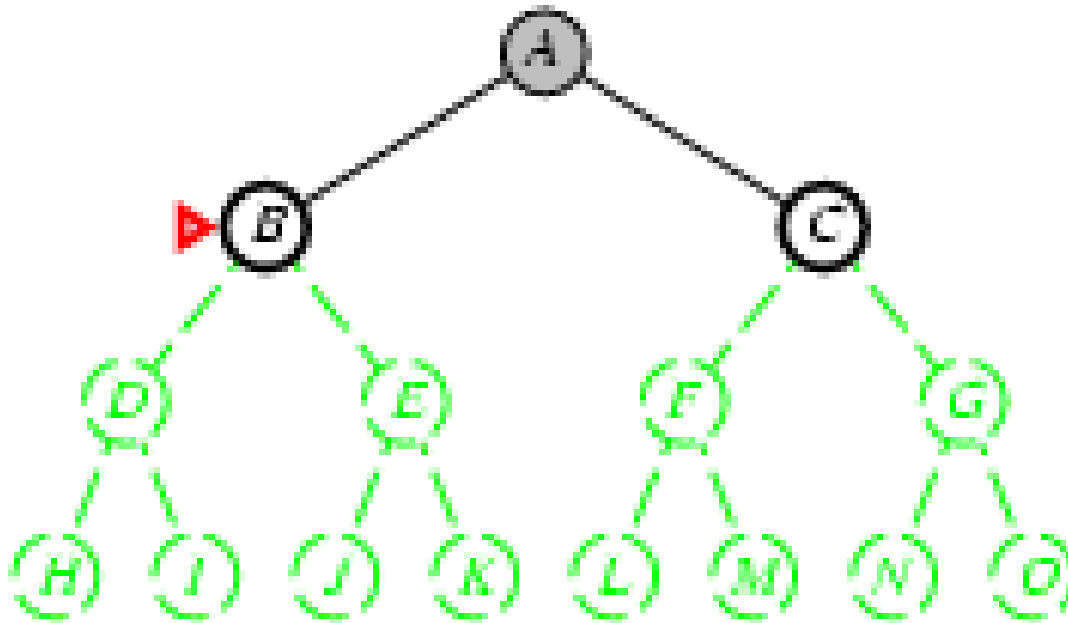

Depth-first search

- Expand deepest unexpanded node
- **Implementation:**
 - *frontier* = LIFO queue, i.e., put successors at front

queue=[D,E,C]

Is D = goal state?

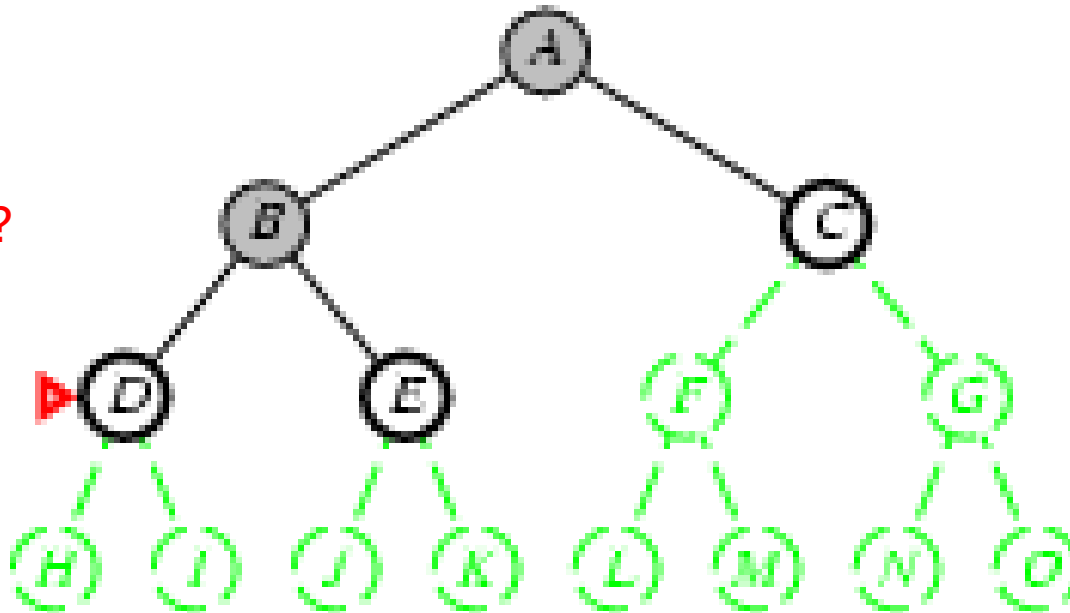

Depth-first search

- Expand deepest unexpanded node
- **Implementation:**
 - *frontier* = LIFO queue, i.e., put successors at front

queue=[H,I,E,C]

Is H = goal state?

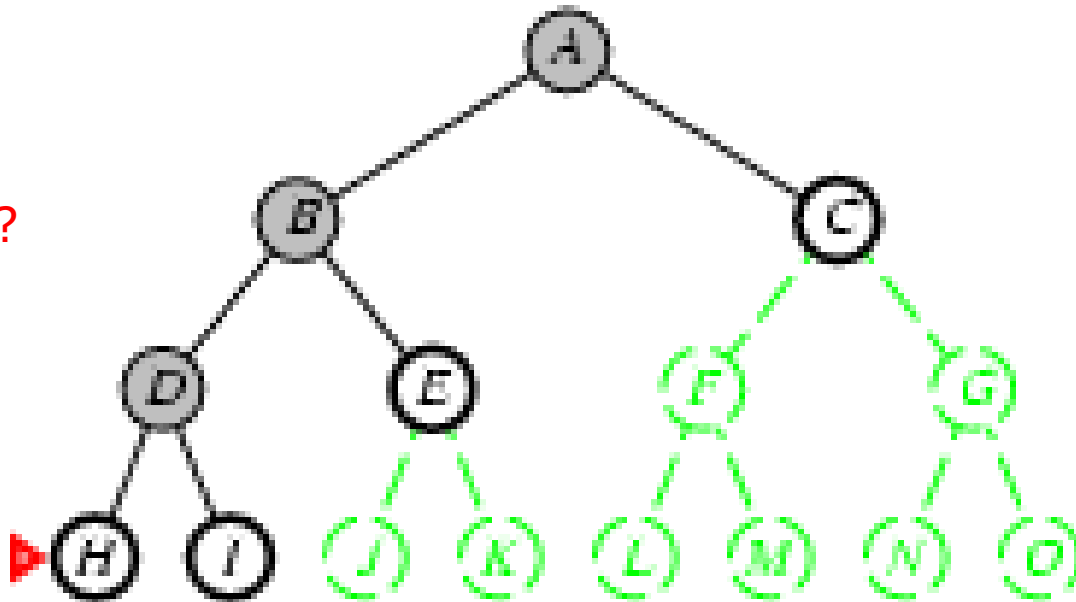

Depth-first search

- Expand deepest unexpanded node
- **Implementation:**
 - *frontier* = LIFO queue, i.e., put successors at front

queue=[I,E,C]

Is I = goal state?

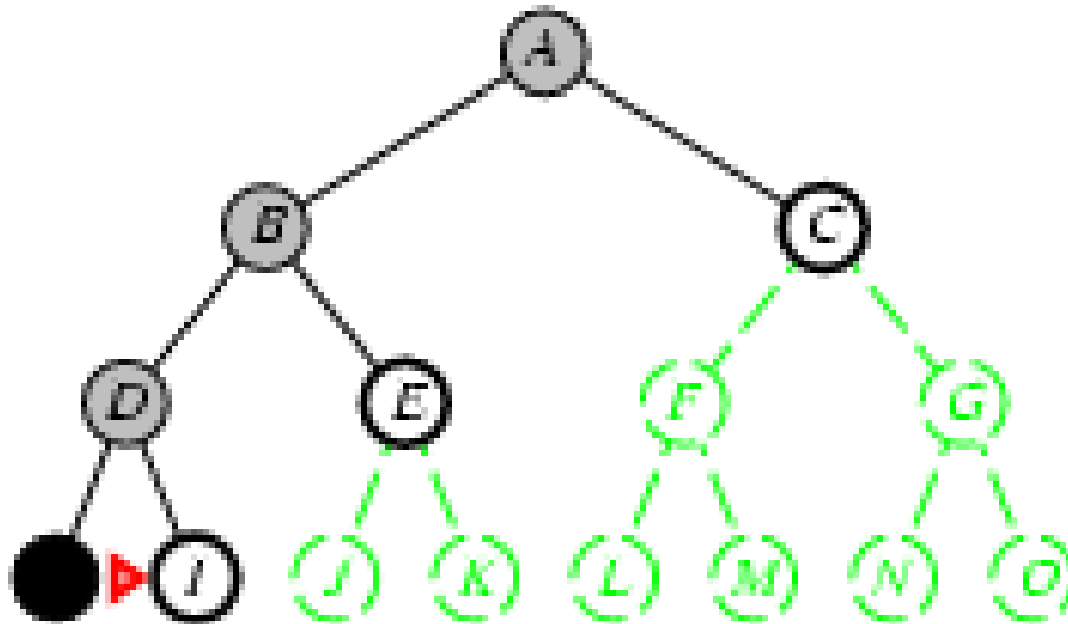

Depth-first search

- Expand deepest unexpanded node
- **Implementation:**
 - *frontier* = LIFO queue, i.e., put successors at front

queue=[E,C]

Is E = goal state?

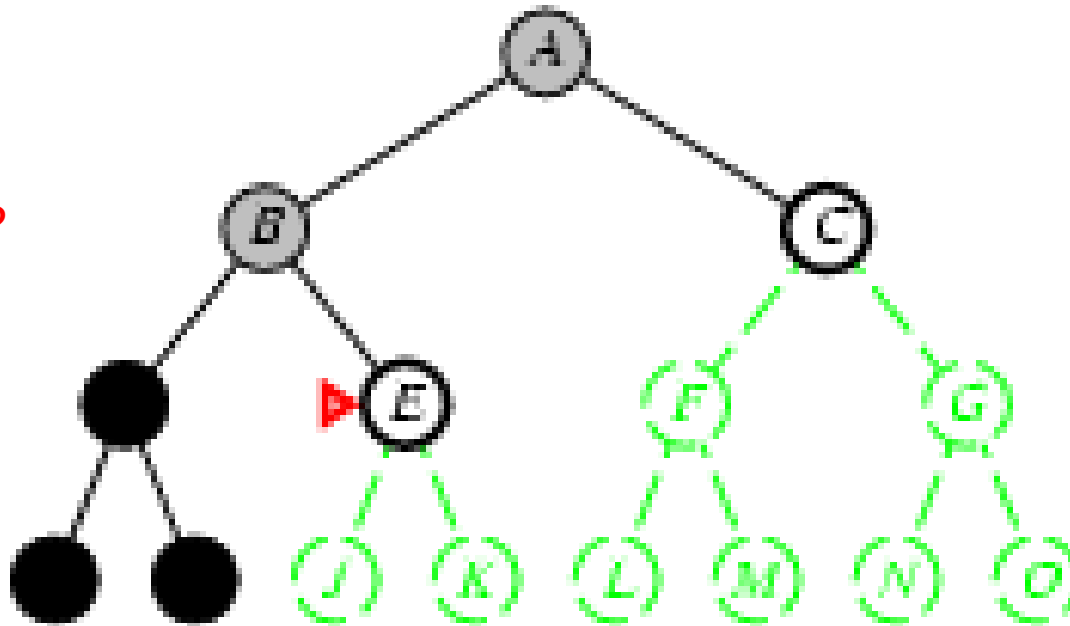

Depth-first search

- Expand deepest unexpanded node
- **Implementation:**
 - *frontier* = LIFO queue, i.e., put successors at front

queue=[J,K,C]

Is J = goal state?

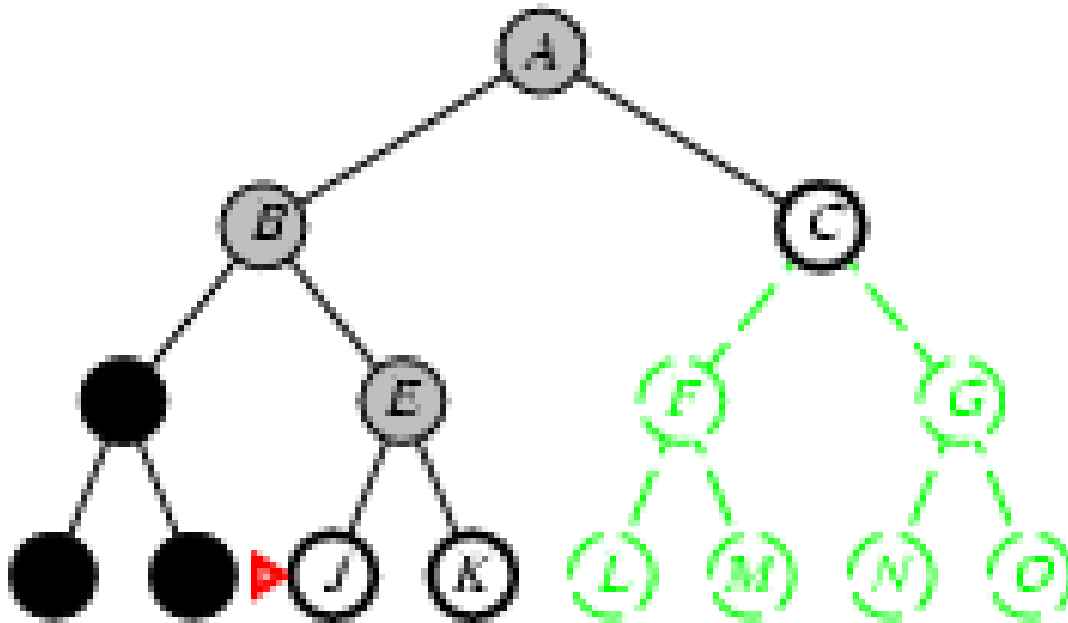

Depth-first search

- Expand deepest unexpanded node
- **Implementation:**
 - *frontier* = LIFO queue, i.e., put successors at front

queue=[K,C]

Is K = goal state?

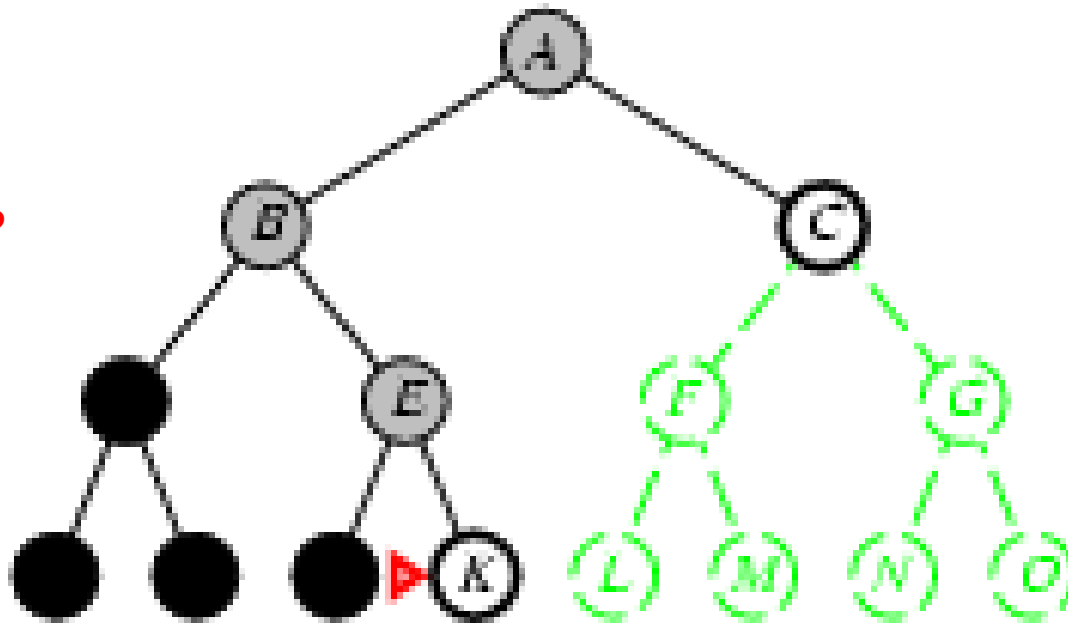

Depth-first search

- Expand deepest unexpanded node
- **Implementation:**
 - *frontier* = LIFO queue, i.e., put successors at front

queue=[C]

Is C = goal state?

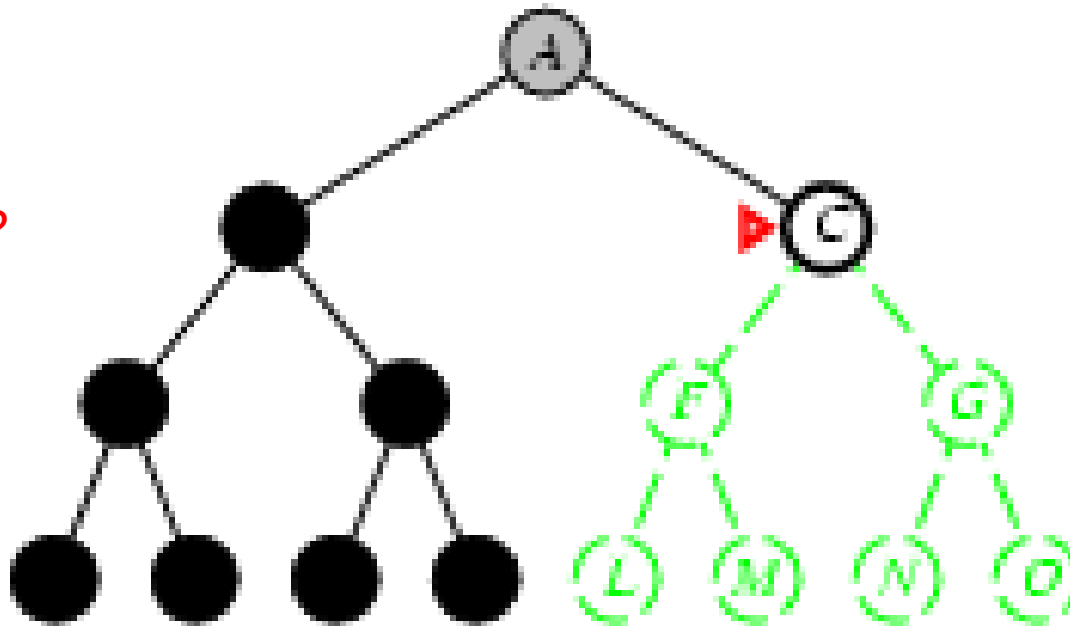

Depth-first search

- Expand deepest unexpanded node
- **Implementation:**
 - *frontier* = LIFO queue, i.e., put successors at front

queue=[F,G]

Is F = goal state?

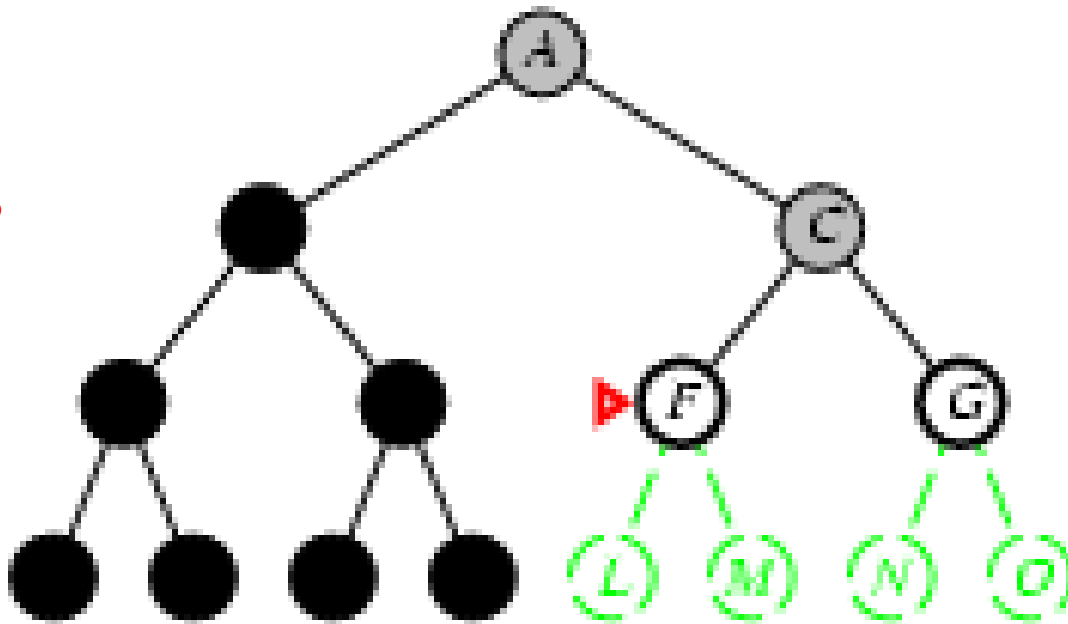

Depth-first search

- Expand deepest unexpanded node
- **Implementation:**
 - *frontier* = LIFO queue, i.e., put successors at front

queue=[L,M,G]

Is L = goal state?

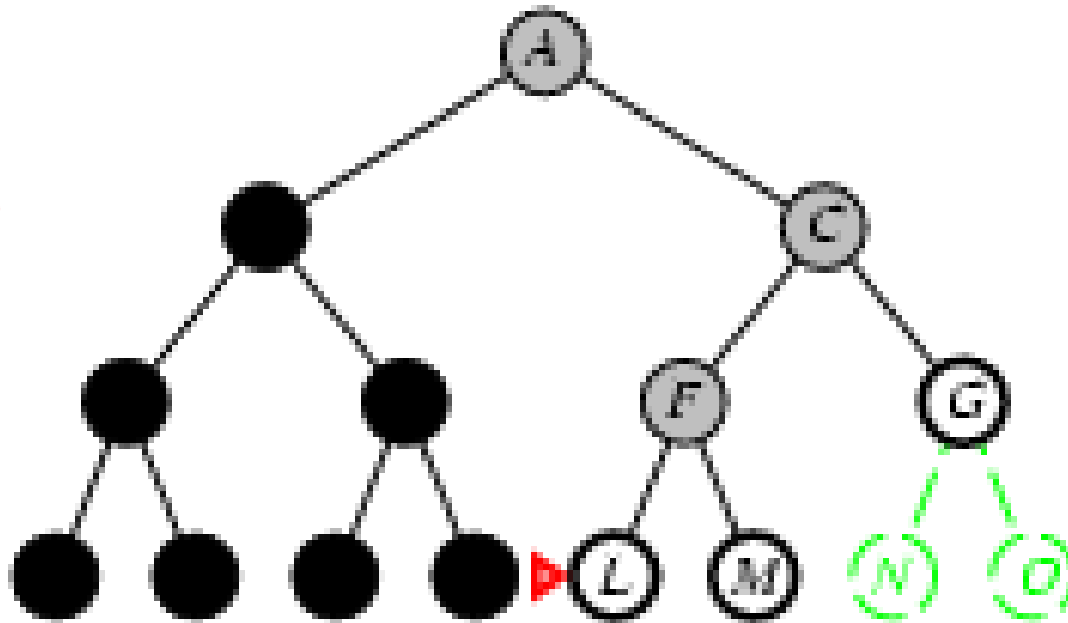

Depth-first search

- Expand deepest unexpanded node
- **Implementation:**
 - *frontier* = LIFO queue, i.e., put successors at front

queue=[M,G]

Is M = goal state?

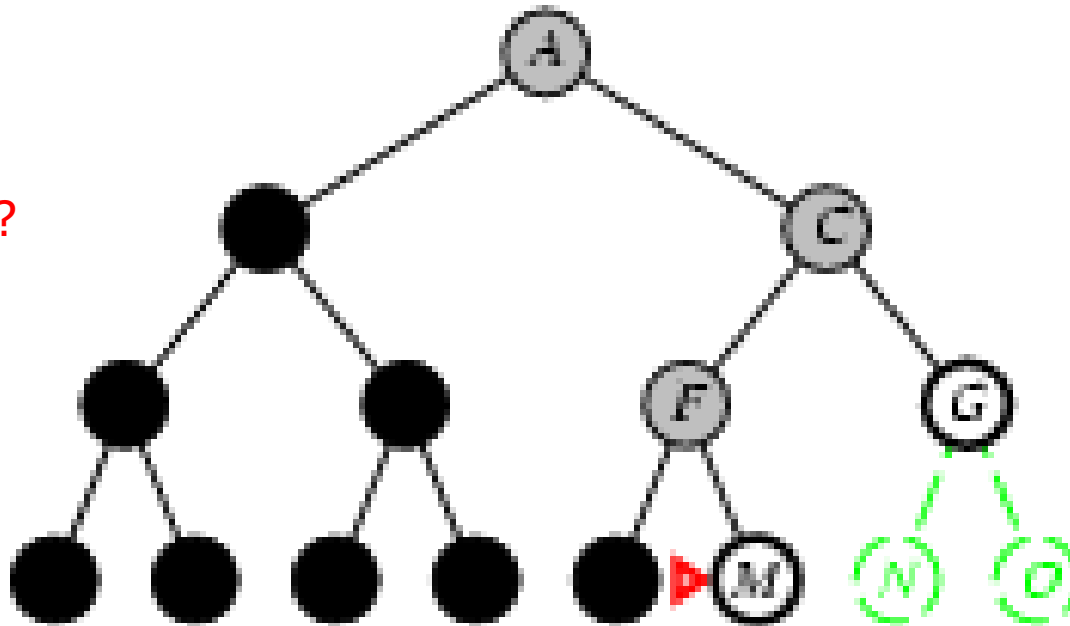

Depth-First Search (DFS)

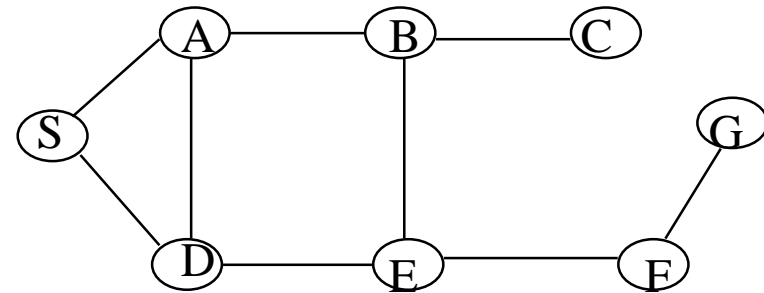
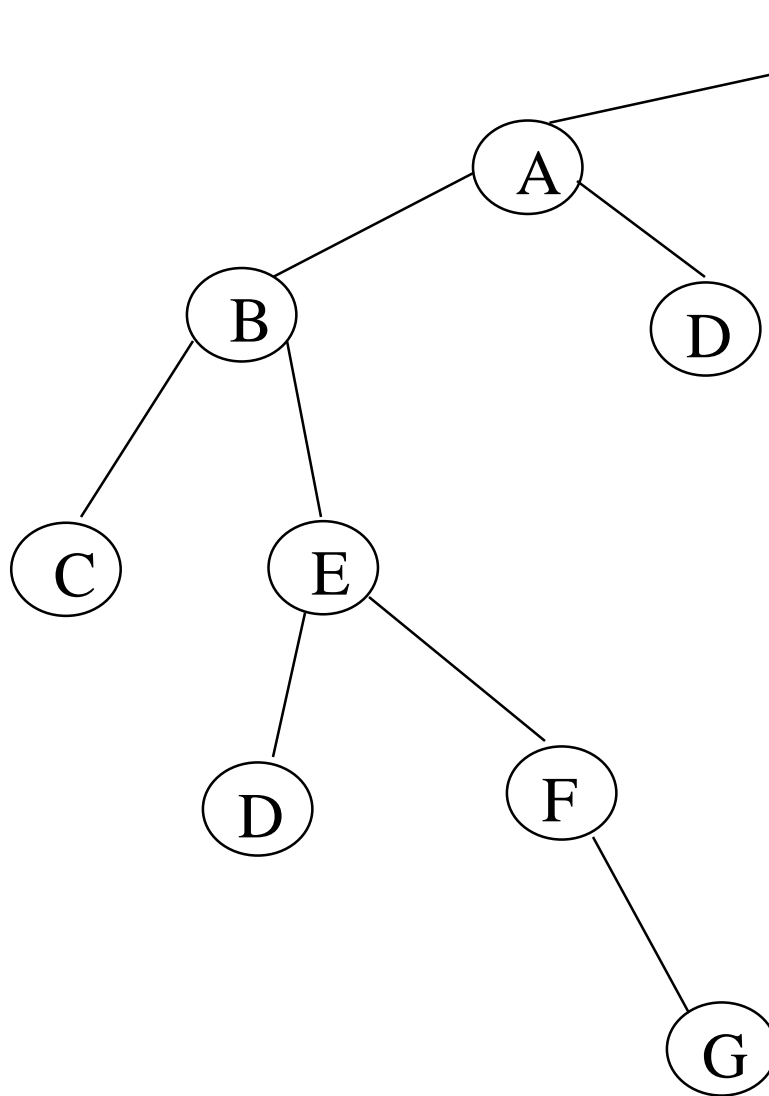

Here, (if tree-search) then to avoid infinite depth (in case of finite state-space graph) assume we don't expand any child node which appears already in the path from the root S to the parent. (Again, one could use other strategies)

Depth-First Search

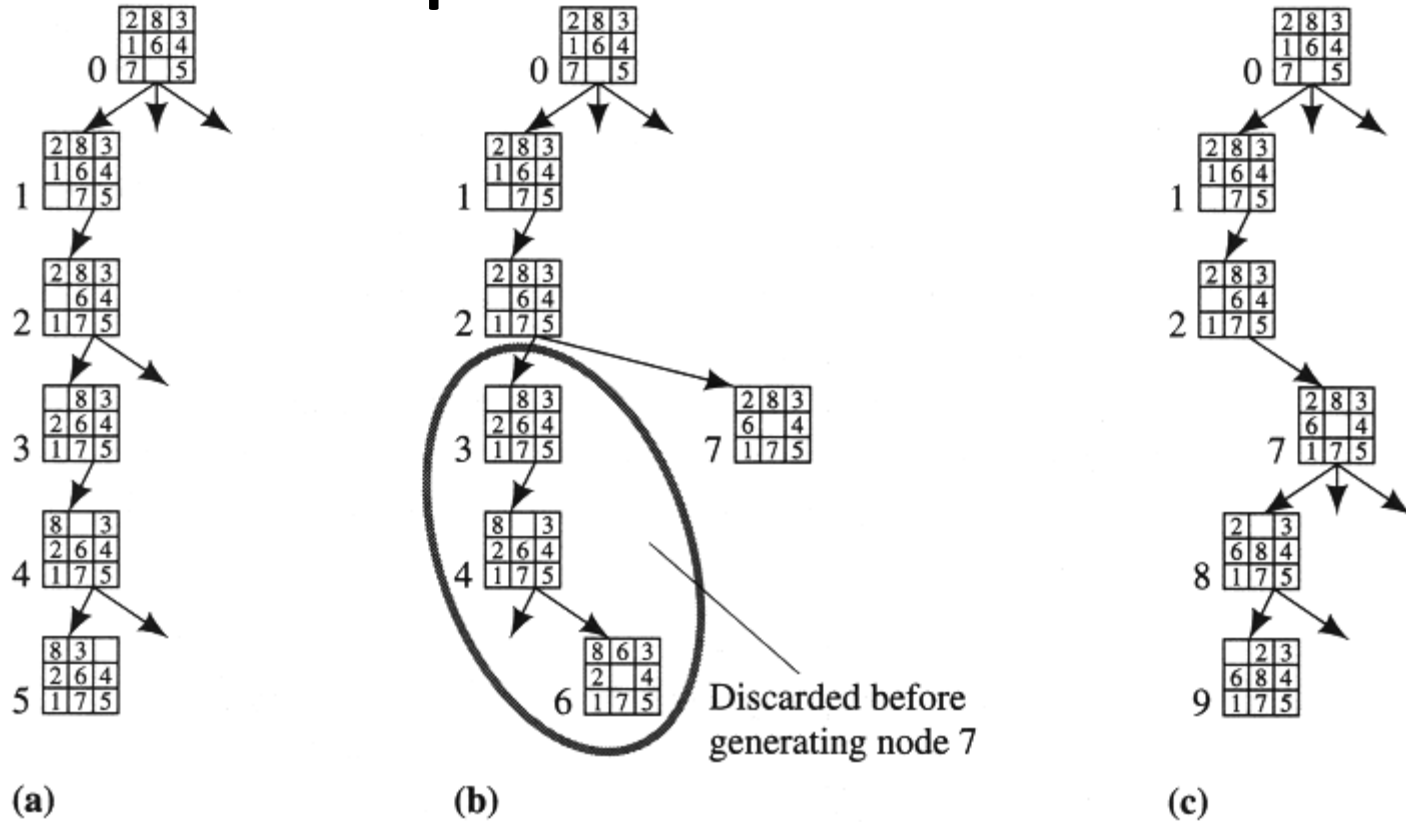

Generation of the First Few Nodes in a Depth-First Search

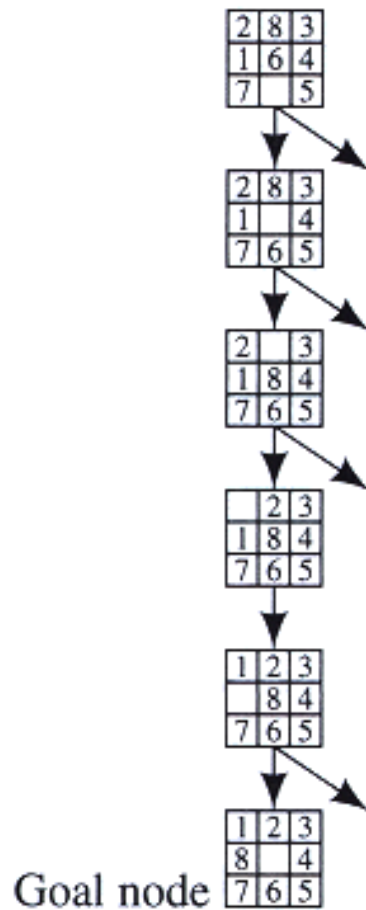

The Graph When the Goal Is Reached in Depth-First Search

Depth-First-Search (*)

1. Put the start node s on OPEN
2. If OPEN is empty exit with failure.
3. Remove the first node n from OPEN.
4. If n is a goal node, exit successfully with the solution obtained by tracing back pointers from n to s .
5. Otherwise, expand n , generating all its successors (check for self-loops) attach to them pointers back to n , and put them at the top of OPEN *in some order*.
6. Go to step 2.

*search the tree search-space (but avoid self-loops)

** the default assumption is that DFS searches the underlying search-tree

Complexity of Depth-First Search?

- Time Complexity
 - assume d is deepest path in the search space
 - assume (worst case) that there is 1 goal leaf at the RHS
 - so DFS will expand all nodes

$$= 1 + b + b^2 + \dots + b^d$$

$$= O(b^d)$$

- Space Complexity (for tree-search)
 - how many nodes can be in the queue (worst-case)?
 - **$O(bd)$ if deepest node at depth d**

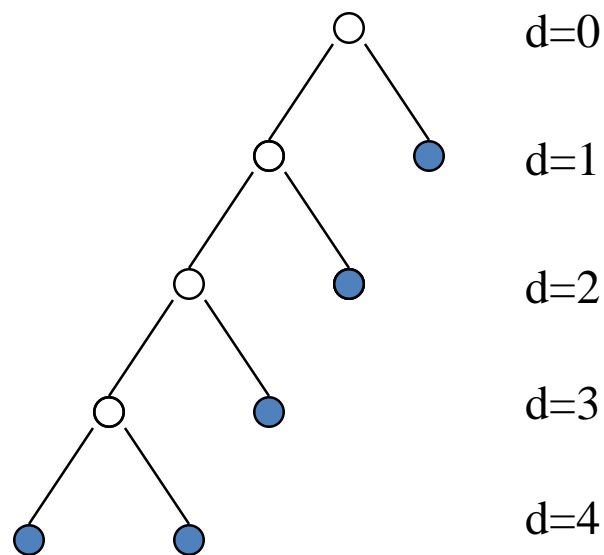
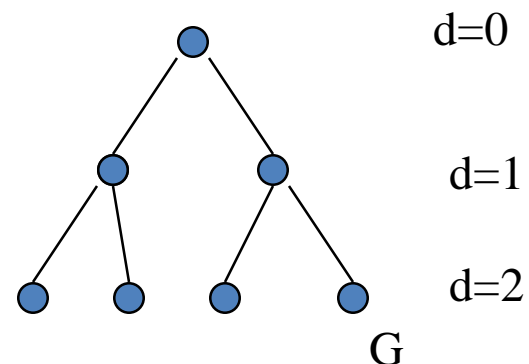

Example, Diamond Networks

graph-search vs tree-search (BFS vs DFS)

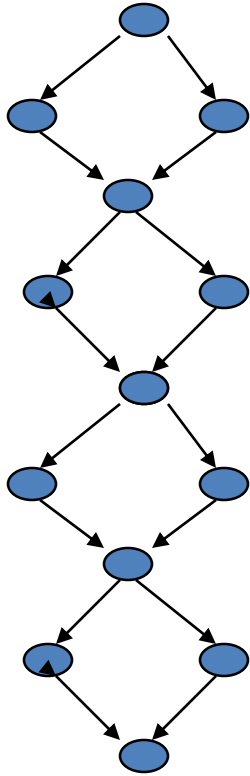

- Graph-search & BFS
- Tree-search & DFS

Depth-First tree-search Properties

- Non-optimal solution path
- Incomplete unless there is a depth bound
- (we will assume depth-limited DF-search)
- Re-expansion of nodes (when the state-space is a graph)
- Exponential time
- Linear space (for tree-search)

Comparing DFS and BFS

- BFS optimal, DFS is not
- Time Complexity worse-case is the same, but
 - In the worst-case BFS is always better than DFS
 - Sometimes, on the average DFS is better if:
 - many goals, no loops and no infinite paths
- BFS is much worse memory-wise
 - DFS can be linear space
 - BFS may store the whole search space.
- In general
 - BFS is better if goal is not deep, if long paths, if many loops, if small search space
 - DFS is better if many goals, not many loops
 - DFS is much better in terms of memory

Iterative-Deepening Search (DFS)

- Every iteration is a DFS with a depth cutoff.

Iterative deepening (ID)

1. $i = 1$
2. While no solution, do
3. DFS from initial state S_0 with cutoff i
4. If found goal, stop and return solution, else, increment cutoff

Comments:

- IDS implements BFS with DFS
- Only one path in memory
- BFS at step i may need to keep 2^i nodes in OPEN

Iterative deepening search $L=0$

Limit = 0



Iterative deepening search $L=1$

Limit = 1

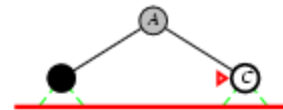
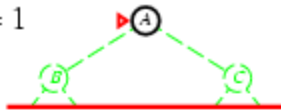

Iterative deepening search $L=2$

Limit = 2

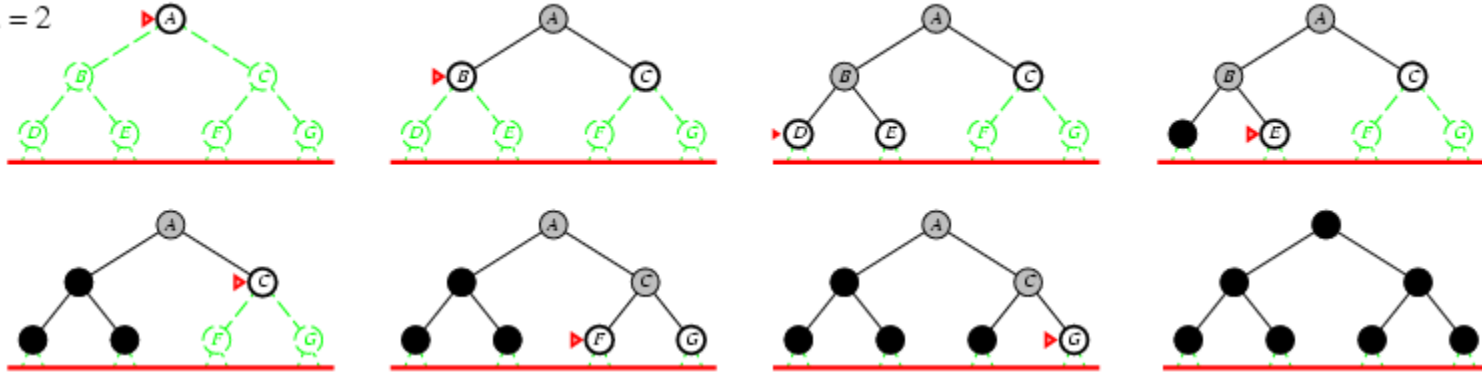

Iterative Deepening Search $L=3$

Limit = 3

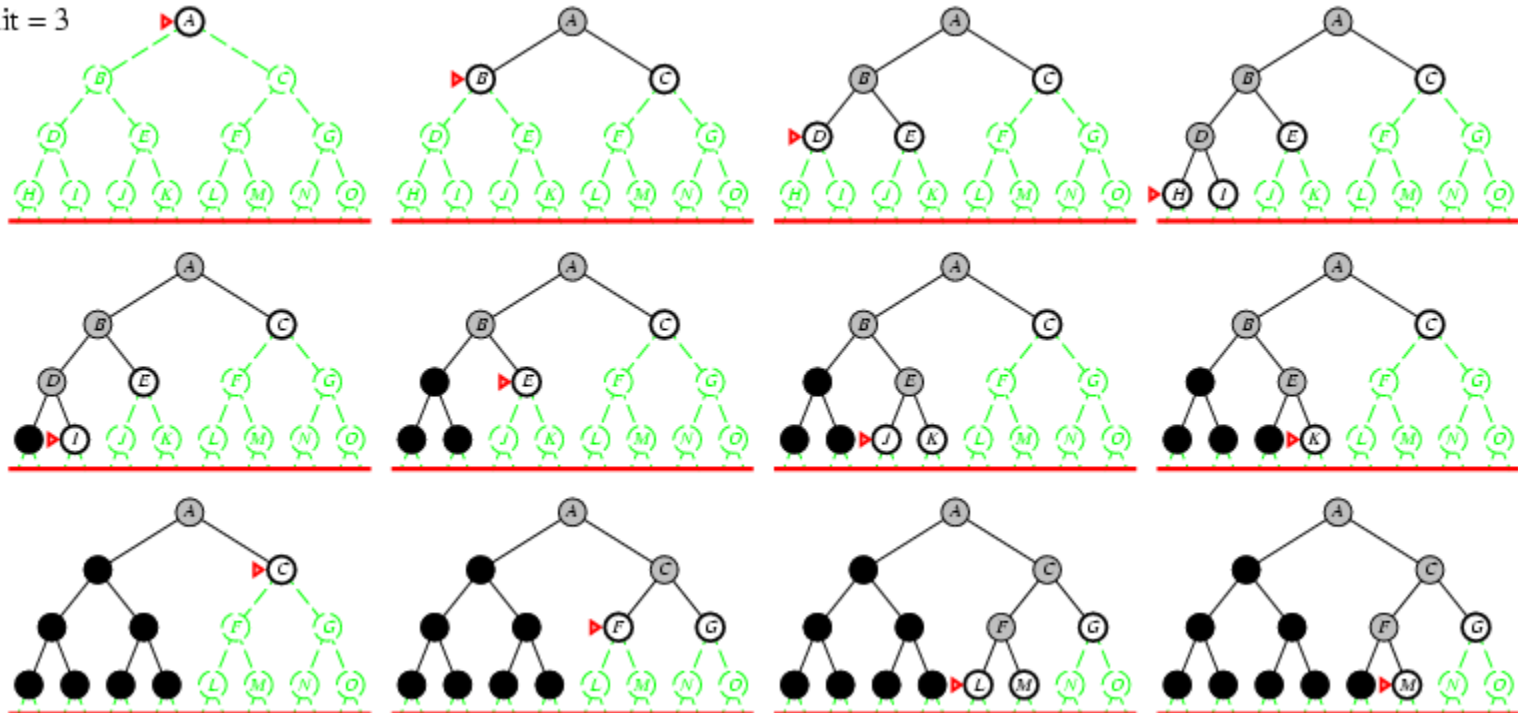

Iterative deepening search

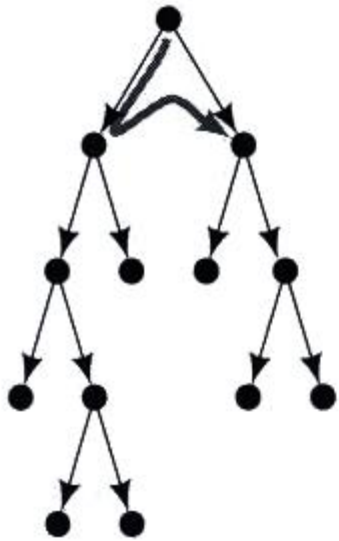

Depth bound = 1

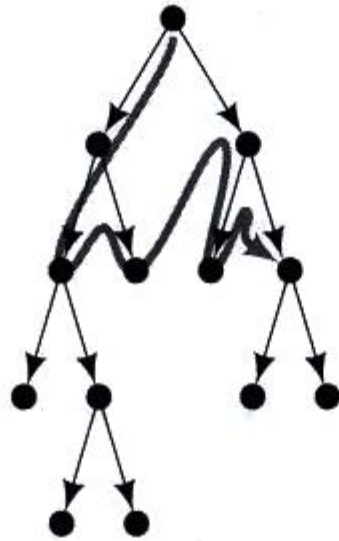

Depth bound = 2

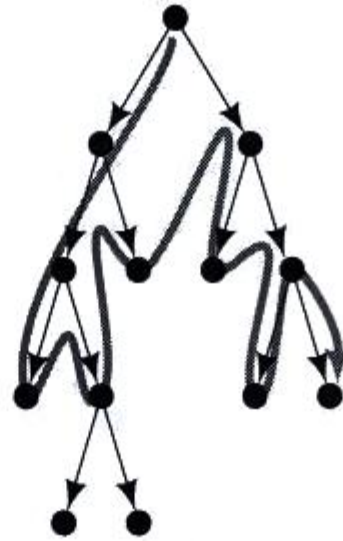

Depth bound = 3

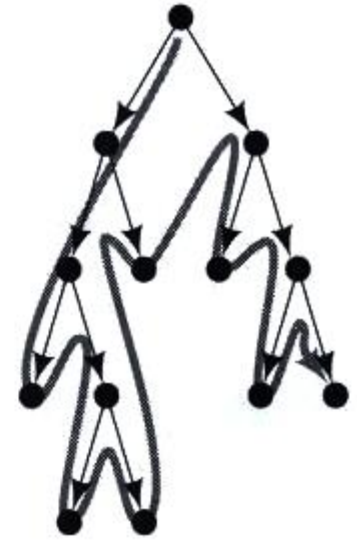

Depth bound = 4

Stages in Iterative-Deepening Search

Iterative Deepening (DFS)

- Time:
$$T(n) = \sum_{j=1}^n \frac{b^{j+1} - 1}{b - 1} = \frac{b^{n+2} - b}{(b-1)^2} = O(b^n)$$

- BFS time is $O(b^n)$, b is the branching degree
- IDS is asymptotically like BFS,
- For $b=10$ $d=5$ $d=\text{cut-off}$
- DFS = 1+10+100,...,=111,111
- IDS = 123,456
- Ratio is $\frac{b}{b-1}$

Summary on IDS

- A useful practical method
 - combines
 - guarantee of finding an optimal solution if one exists (as in BFS)
 - space efficiency, $O(bd)$ of DFS
 - But still has problems with loops like DFS

Bidirectional Search

- Idea
 - simultaneously search forward from S and backwards from G
 - stop when both “meet in the middle”
 - need to keep track of the intersection of 2 open sets of nodes
- What does searching backwards from G mean
 - need a way to specify the predecessors of G
 - this can be difficult,
 - e.g., predecessors of checkmate in chess?
 - what if there are multiple goal states?
 - what if there is only a goal test, no explicit list?
- Complexity
 - time complexity is best: $O(2 b^{(d/2)}) = O(b^{(d/2)})$
 - memory complexity is the same

Bi-Directional Search

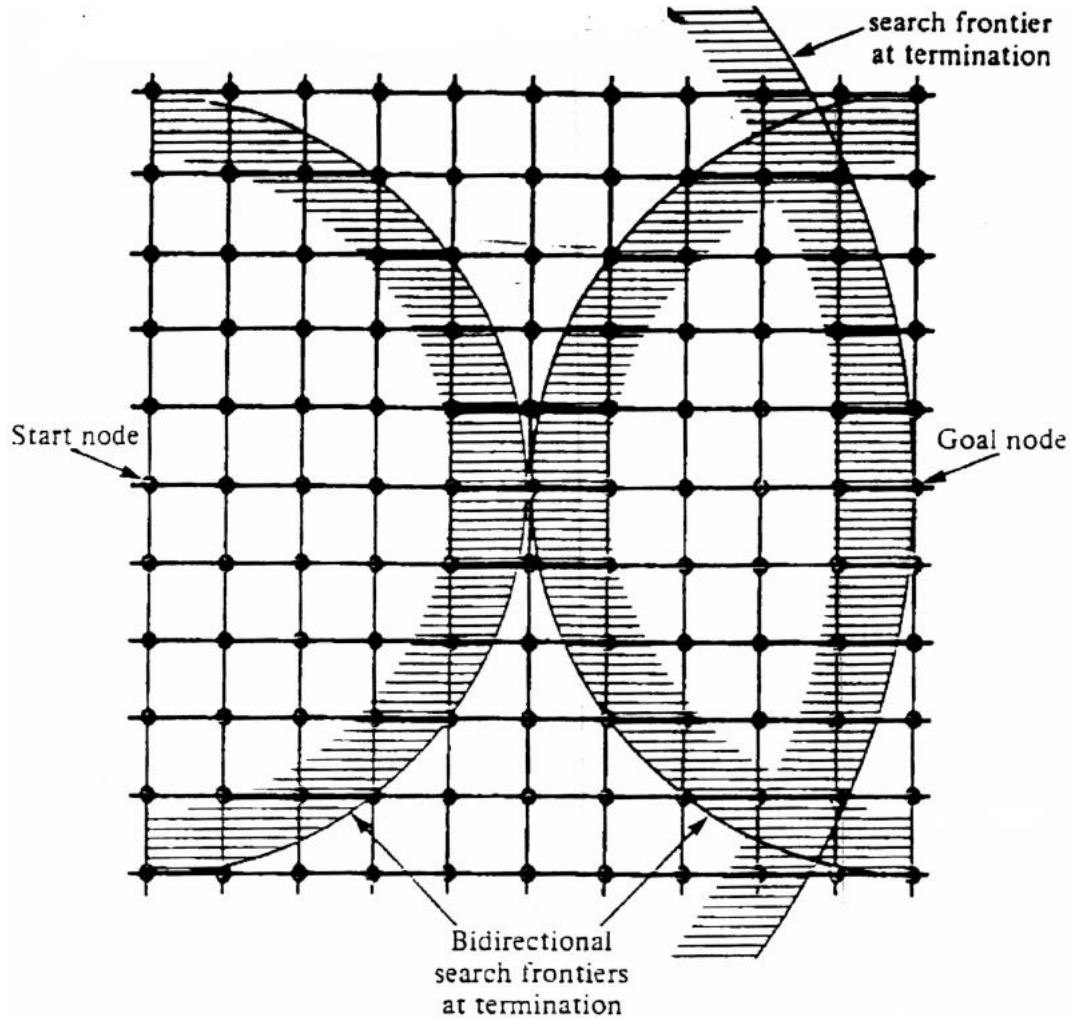

Comparison of Algorithms

Criterion	Breadth-First	Uniform-Cost	Depth-First	Depth-Limited	Iterative Deepening	Bidirectional (if applicable)
Time	b^d	b^d	b^m	b^l	b^d	$b^{d/2}$
Space	b^d	b^d	bm	bl	bd	$b^{d/2}$
Optimal?	Yes	Yes	No	No	Yes	Yes
Complete?	Yes	Yes	No	Yes, if $l \geq d$	Yes	Yes

Figure 3.18 Evaluation of search strategies. b is the branching factor; d is the depth of solution; m is the maximum depth of the search tree; l is the depth limit.

Summary

- A review of search
 - a search space consists of nodes and operators: it is a tree/graph
- There are various strategies for “uninformed search”
 - breadth-first
 - depth-first
 - iterative deepening
 - bidirectional search
 - Uniform cost search
 - Depth-first branch and bound
- Repeated states can lead to infinitely large search trees
 - we looked at methods for detecting repeated states
- All of the search techniques so far are “blind” in that they do not look at how far away the goal may be: next we will look at informed or heuristic search, which directly tries to minimize the distance to the goal.